



2018
AUTOMOTIVE DESIGN
PORTFOLIO

ABHAY RATADIYA



ABOUT ME



HELLO MY NAME IS ABHAY RATADIYA.
I'M TRANSPORTATION DESIGNER, PHOTOGRAPHER AND MODELLER. SINCE MY CHILDHOOD I'M PASSIONATE ABOUT AUTOMOBILES AESTHETICS.

HOBBIES



EDUCATION

2013-17
DYP-DC SCHOOL OF DESIGN, PUNE

2000-13
DIVINE CHILD HIGH SCHOOL, SURAT

SKILLS

ADOBE PHOTOSHOP
AUTODESK ALIAS AUTOMOTIVE
AUTODESK SHOWCASE
AUTODESK VRED DESIGN
CREATIVE THINKING
DESIGN RESEARCH
FREE HAND SKETCHING
MARKER RENDERING
MS OFFICE

EXPERIENCE

6 MONTHS INTERNSHIP -
WIPRO TEC. PVT. LTD. (2017)

2 MONTHS INTERNSHIP -
S.J CRAFT, SURAT (2015)

LANGUAGES

ENGLISH
HINDI
GUJARATI

CONTACT

+91 9545991337
abhay.ratadiya95@gmail.com

01
VITESSE

MAHINDRA TRACTORS

02

03
ADC-15

RE-LEAF

04

misc 05
MISCELLANEOUS

VITESSE





HATCHBACK



COUPE SEDAN



SPORTS CAR

SELECTED BODY TYPE

DIFFERENT BODY STYLE?



MAJOR COMPETITOR



REBECCA JACKSON

AGE - 34

TELEVISION PRESENTER AND RACING DRIVER

UNMARRIED

ADVENTUROUS, BOLD, CLASSY

WEEKDAY REVIEWING AUTOMOBILE AND WEEKEND RACING

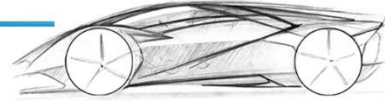
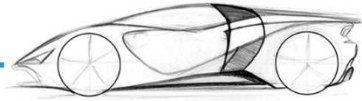
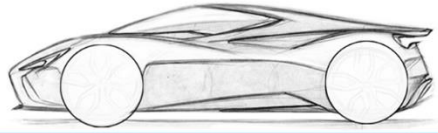

BOLD / TOUGH

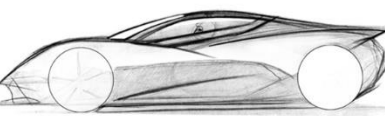
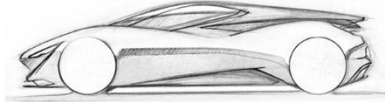
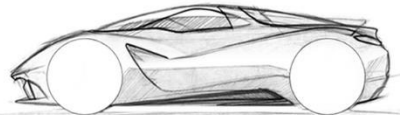
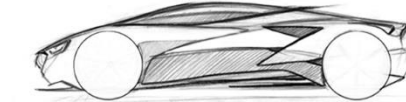
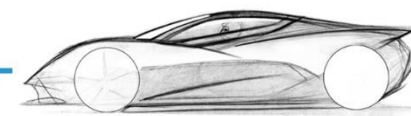
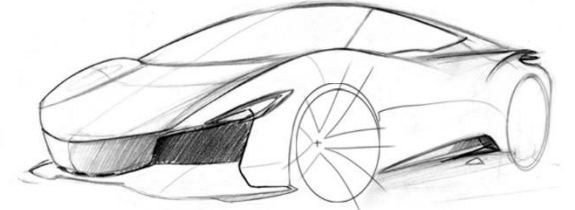
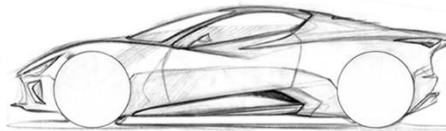
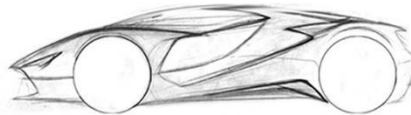
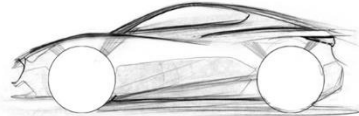
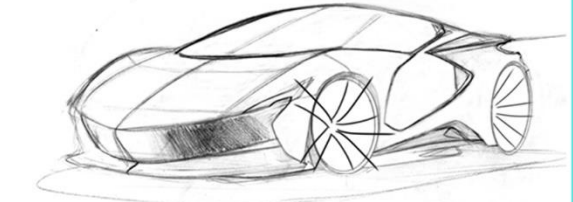
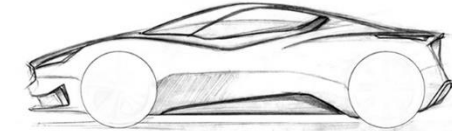
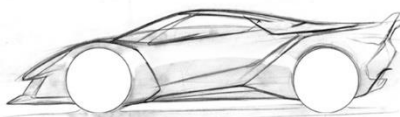
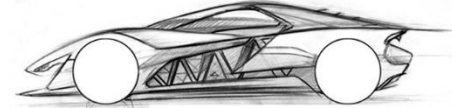
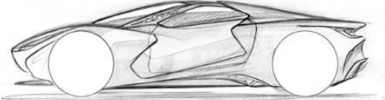
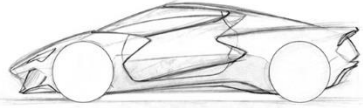

KEY SKETCH'S

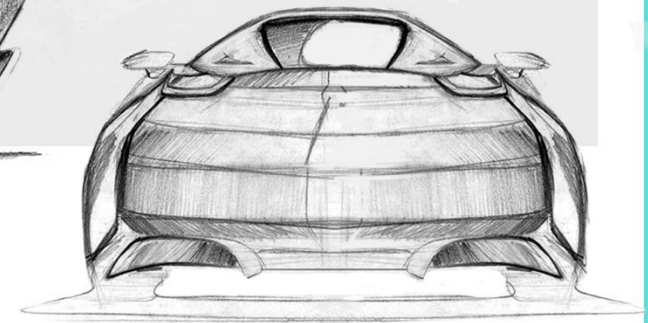
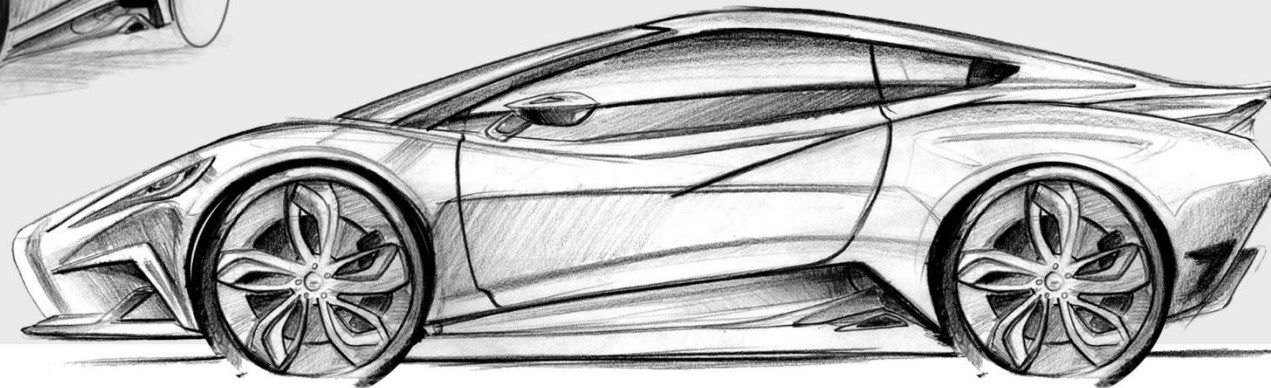
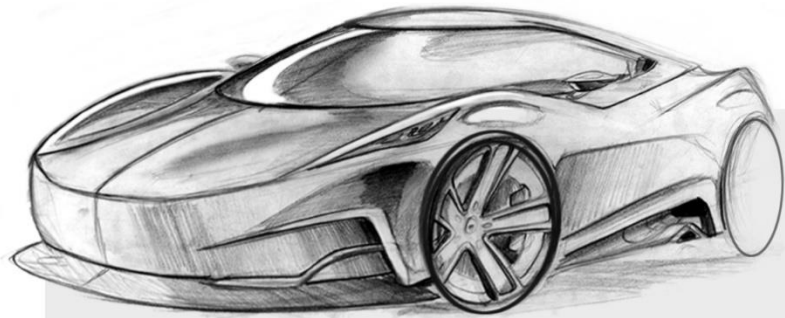
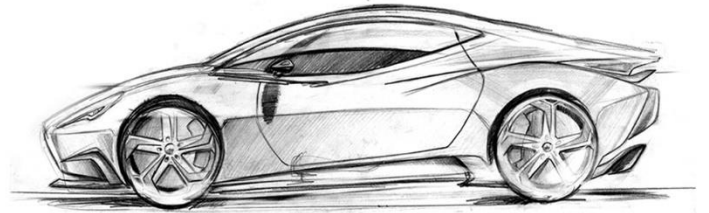
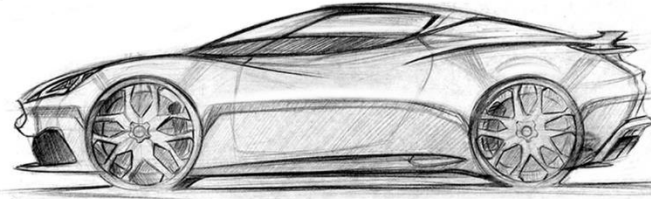
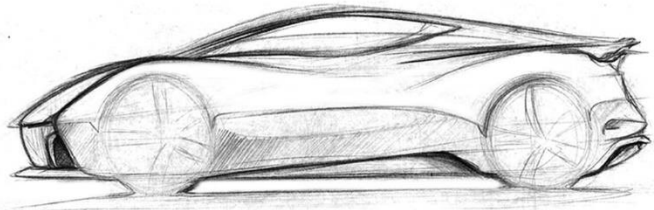

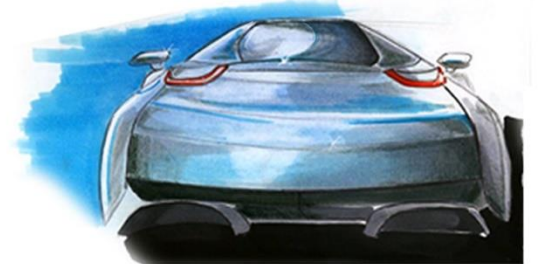
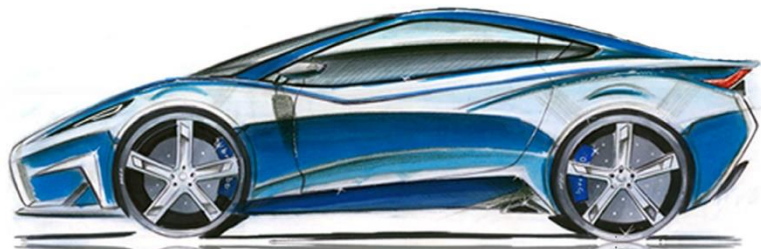
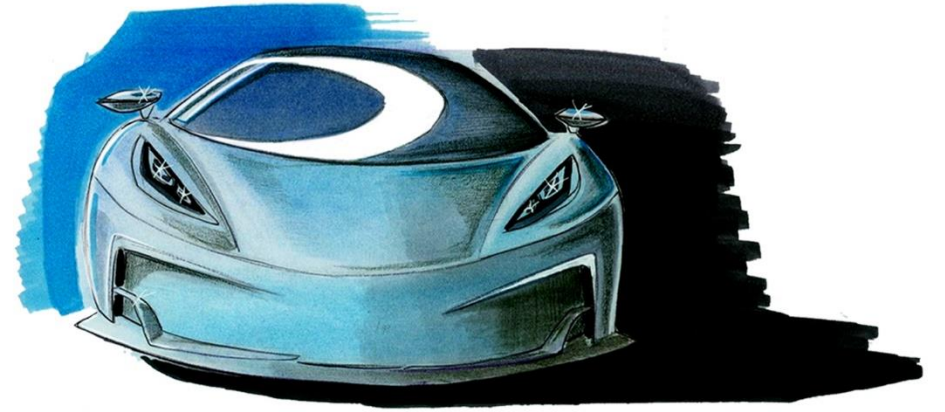
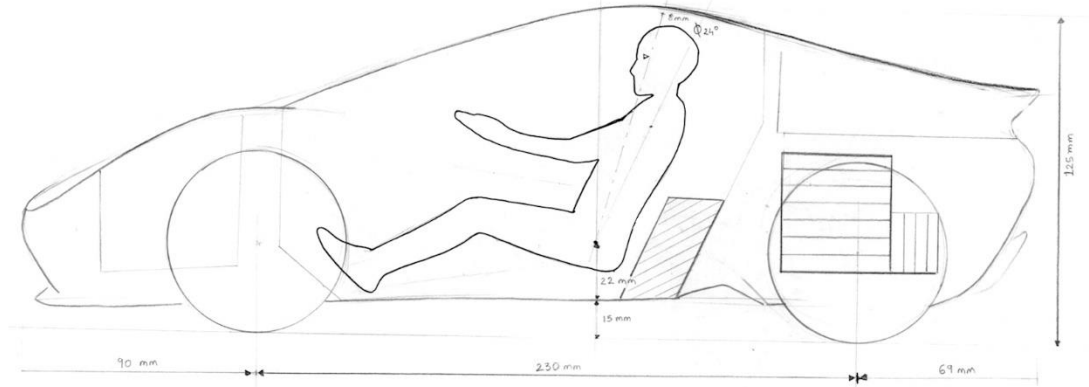
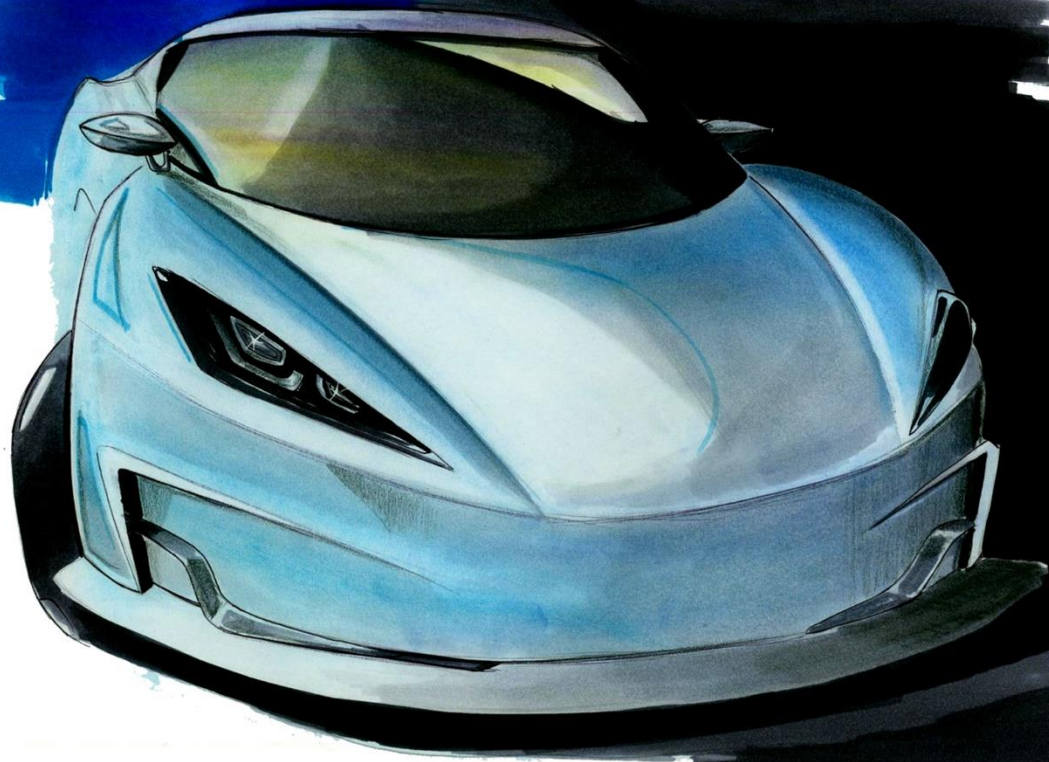

EXTERIOR

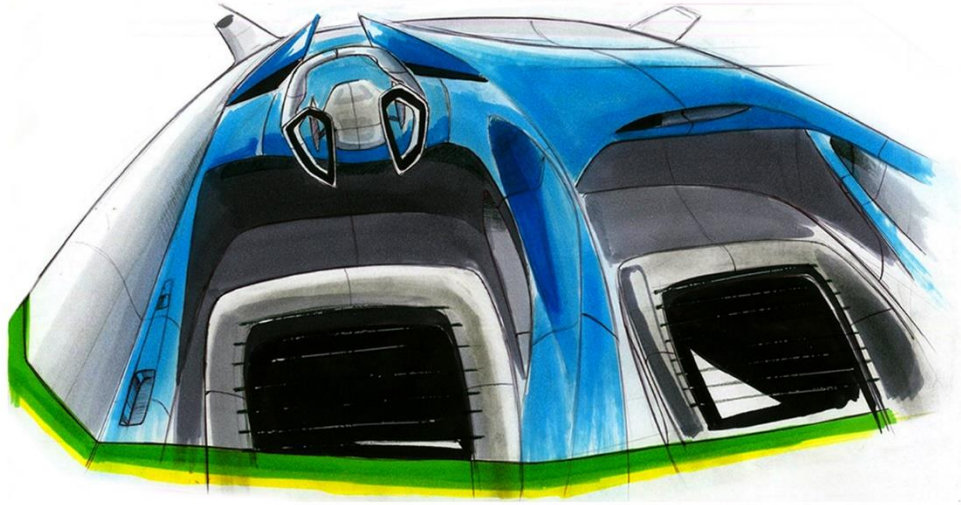
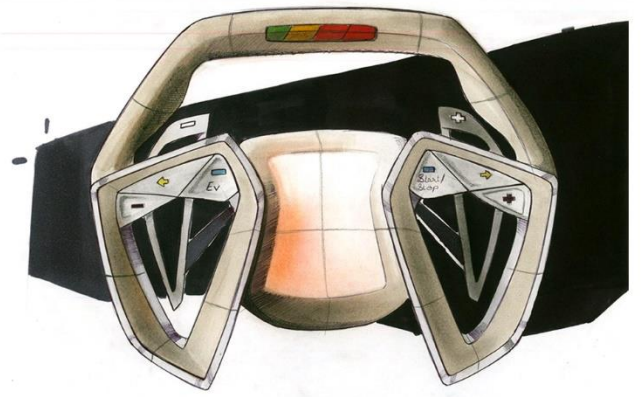
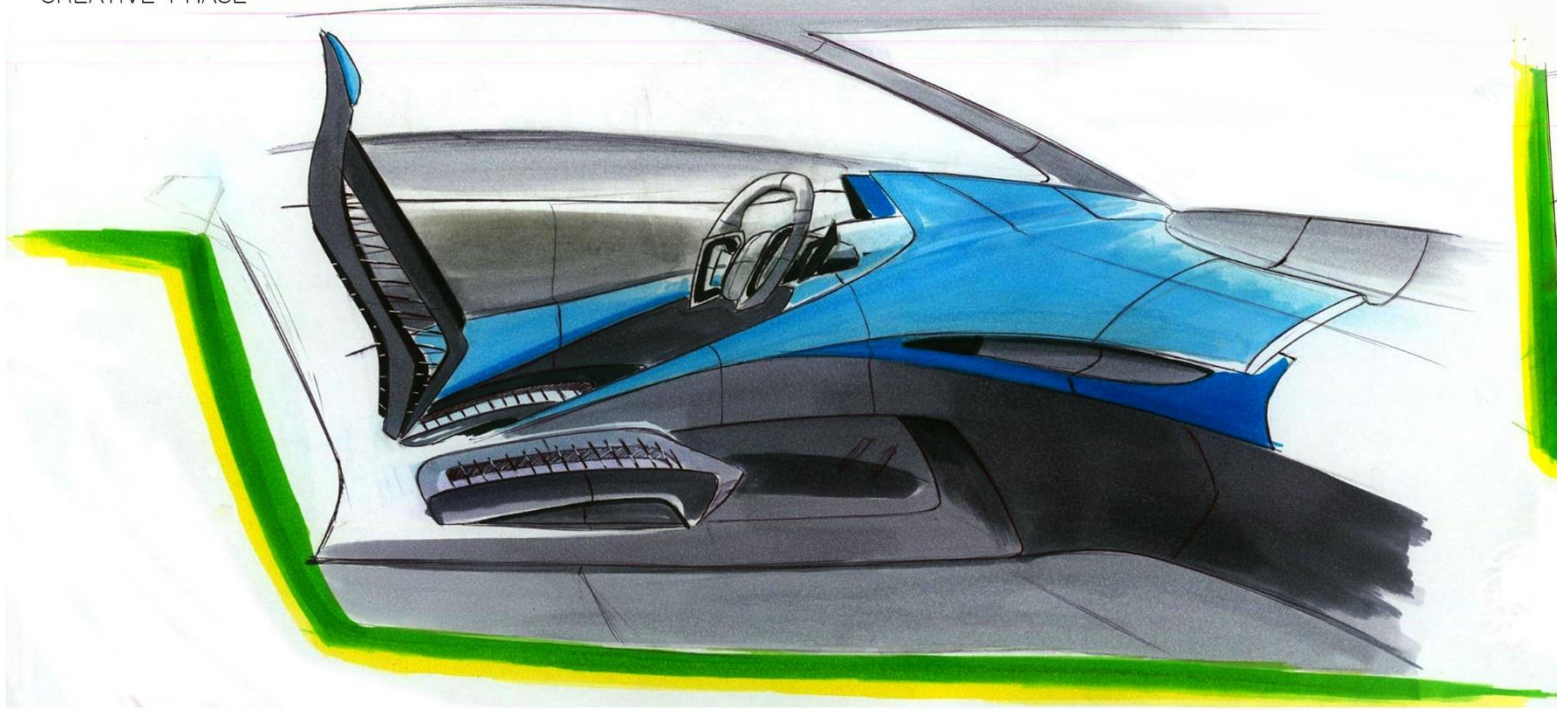

INTERIOR

MAHINDRA TRACTORS



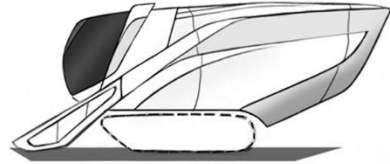
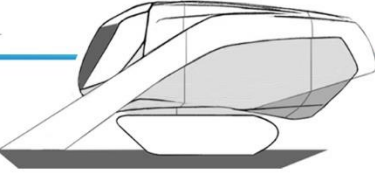
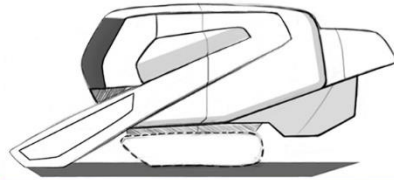
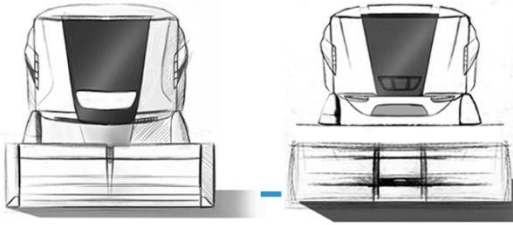

STYLING AROUND PACKAGE GIVEN

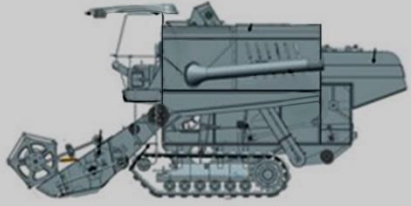

INSPIRATION

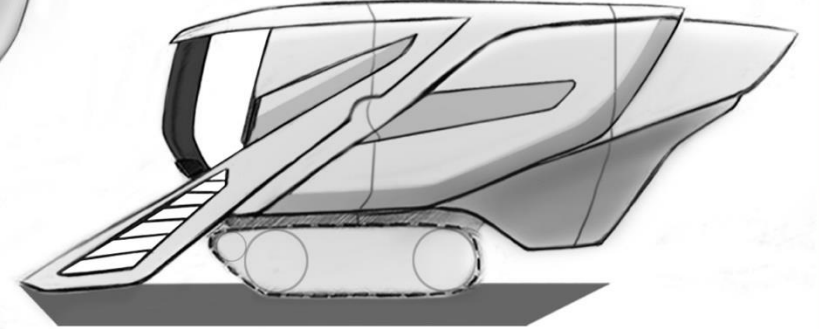
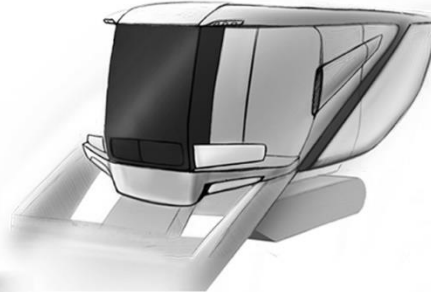

SELECTED CONCEPT

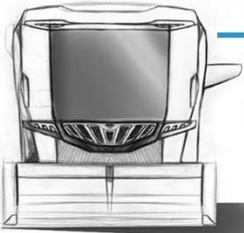
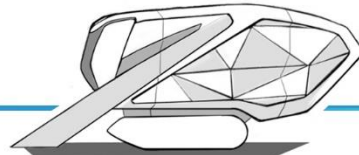
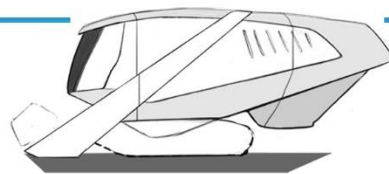
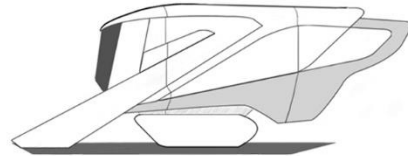
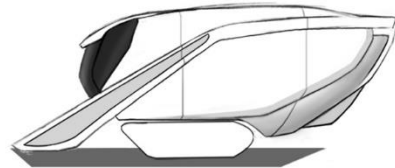

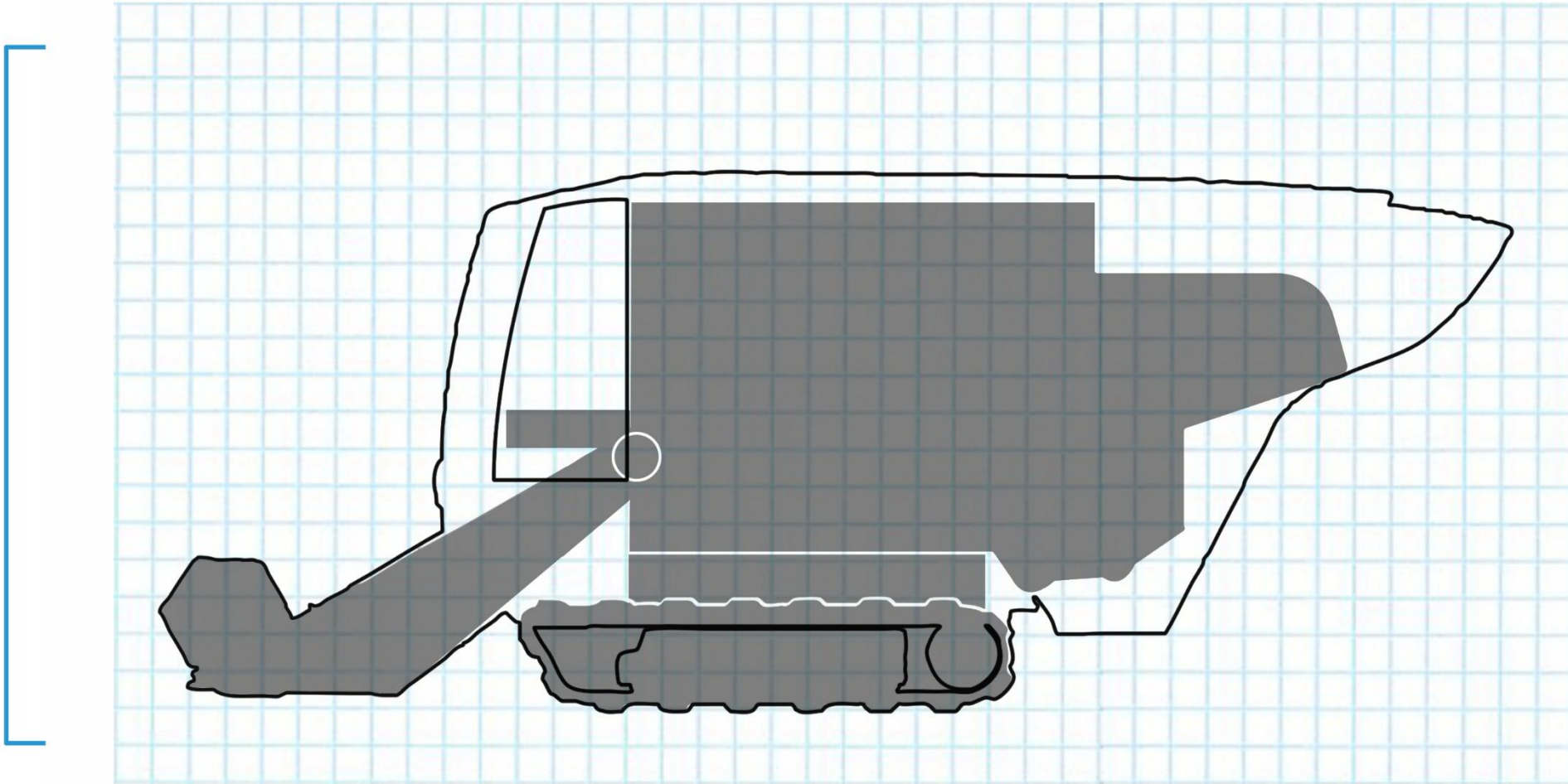

■ GIVEN PACKAGE

— STYLING

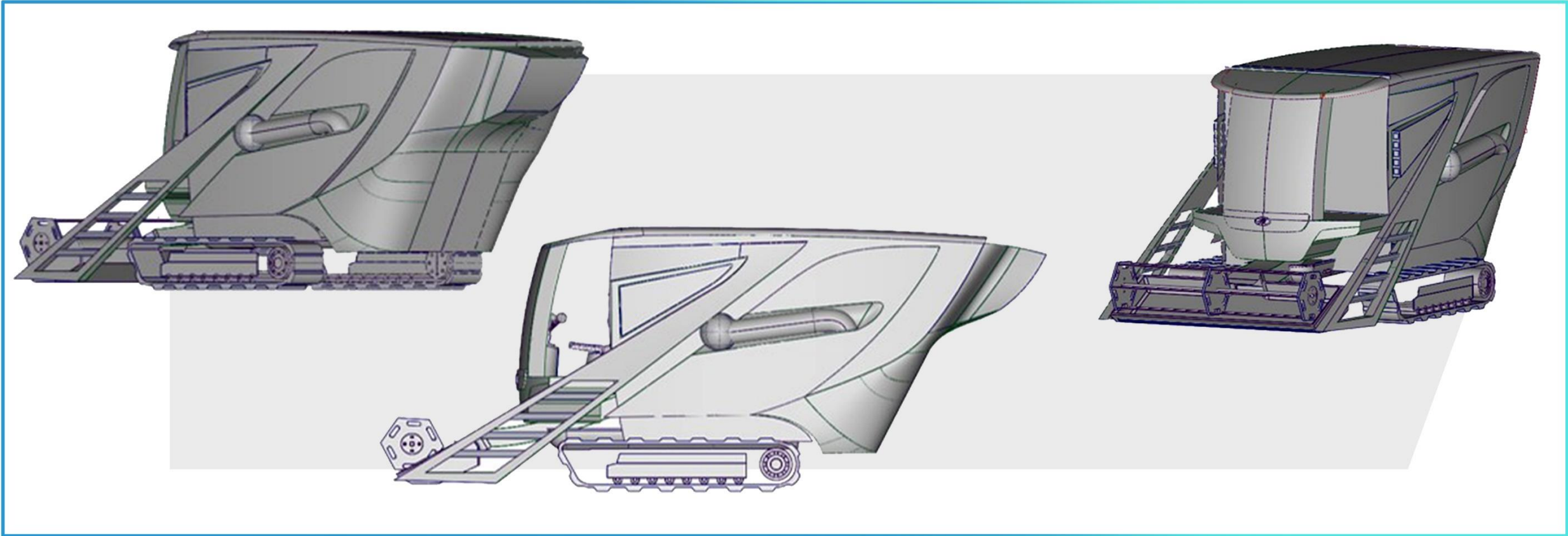

ALIAS MODEL MADE BY RUTVIJ BHAT

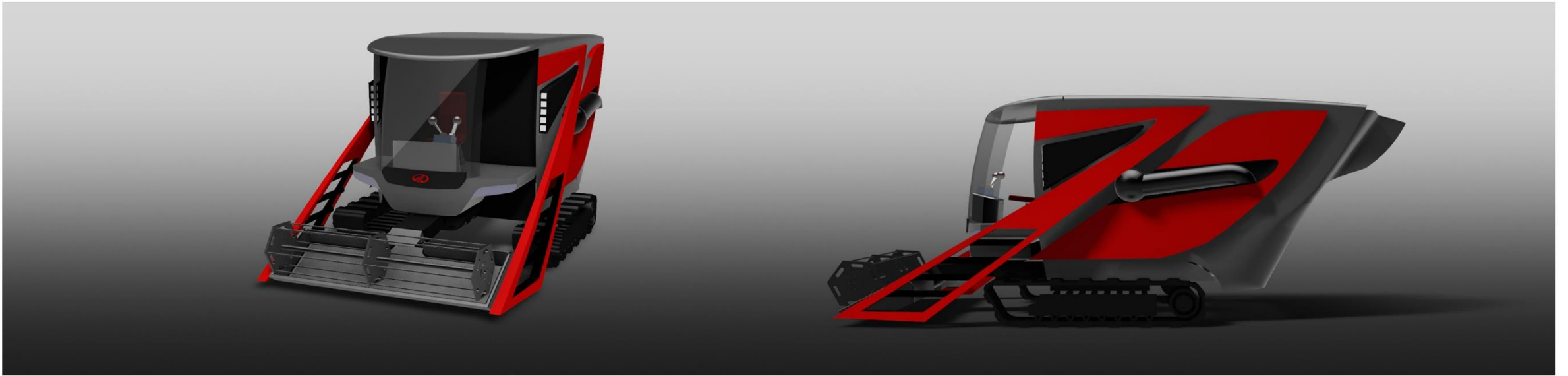
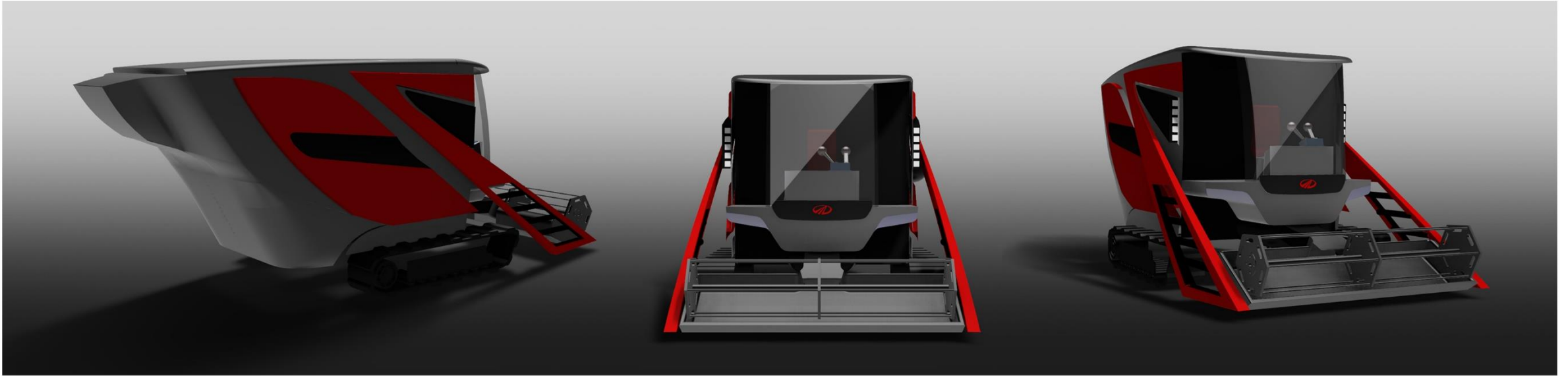

AUTODESK SHOWCASE RENDERS

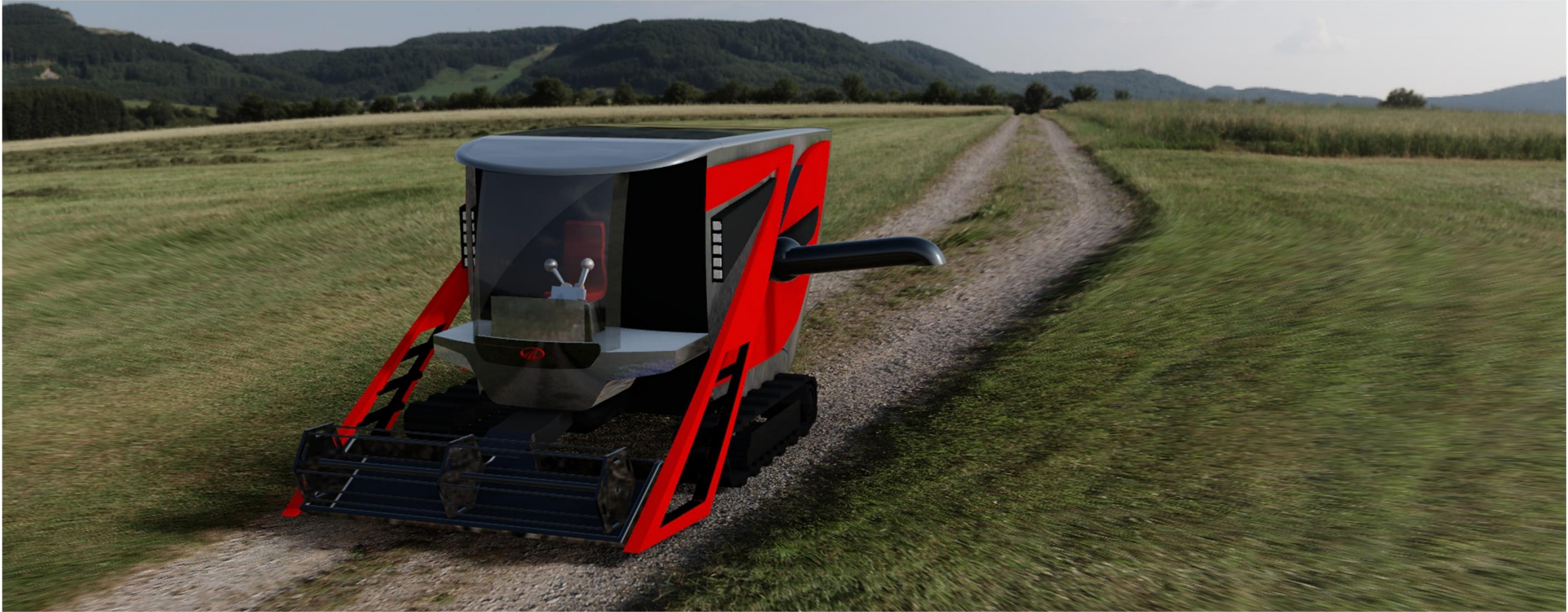

SCENARIOS

ADC - 2015

(ANNUAL DESIGN CONTEST)





KEPLER 186-F 490 LIGHT YEAR
FROM THE EARTH

186-F ORBITING THE RED DWARF-
STAR CALLED KEPLER 186



186-F IS ON THE OUTER EDGE OF THE
HABITABLE ZONE, SO IT IS POSSIBLE
THAT THE PLANET WATER COULD BE
FREEZE



ITS LARGER SIZE, HOWEVER,
COULD MEAN THE PLANET HAS A
THICKER ATMOSPHERE, INSULATING
THE PLANET



186-F TAKES 130 DAYS TO
ORBITS AROUND ITS STAR



THERMAL TEMPERATURE IS
MUCH COOL THAN THE EARTH



186-F IS THE FIRST PLANET WITH A RADIUS SIMILAR TO
EARTH'S TO BE DISCOVERED IN THE HABITABLE ZONE
OF ANOTHER STAR

186-F IS 10TIMES BIGGER IN
VOLUME OF THE EARTH



I HAVE SELECTED BASE.

TO EXPLORE EXO-PLANET WHICH IS FURTHER DOWN THE GALAXY, FINDING THE PLANET WONT BE A SHORT STAY,
HENCE BASE IS ONE OF THE IMPORTANT PART OF THE MISSION

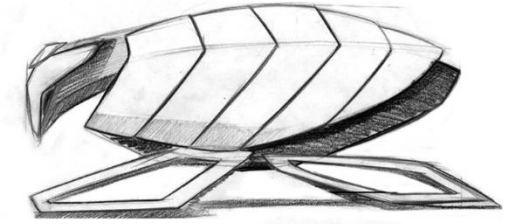
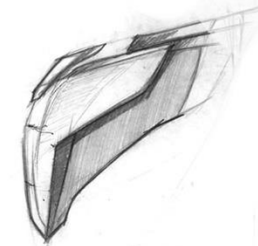
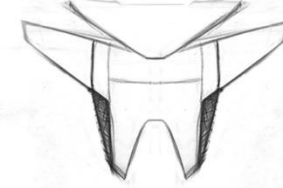
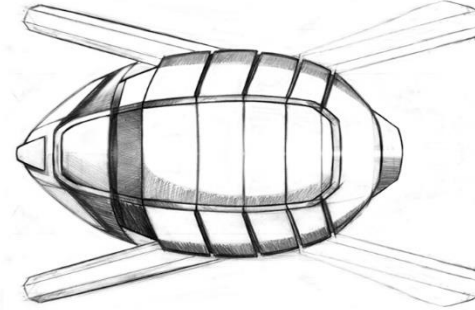
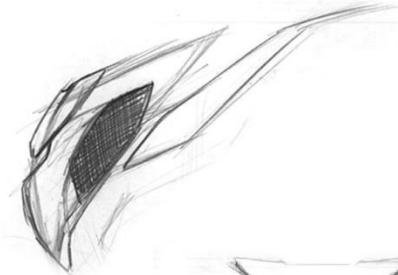
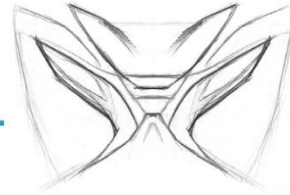
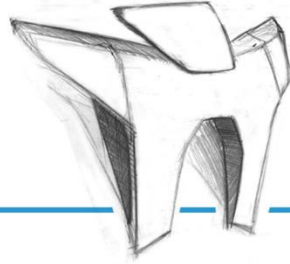
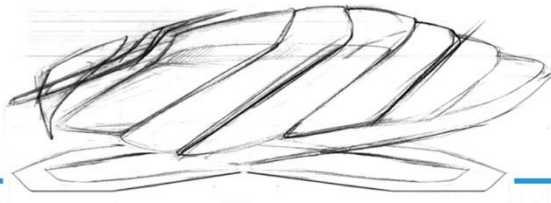

KEY SKETCH

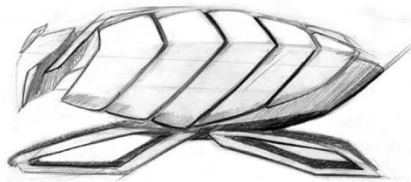
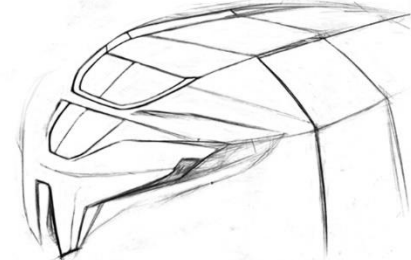
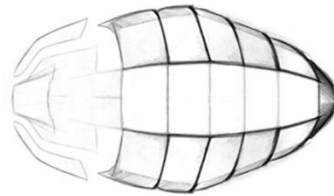

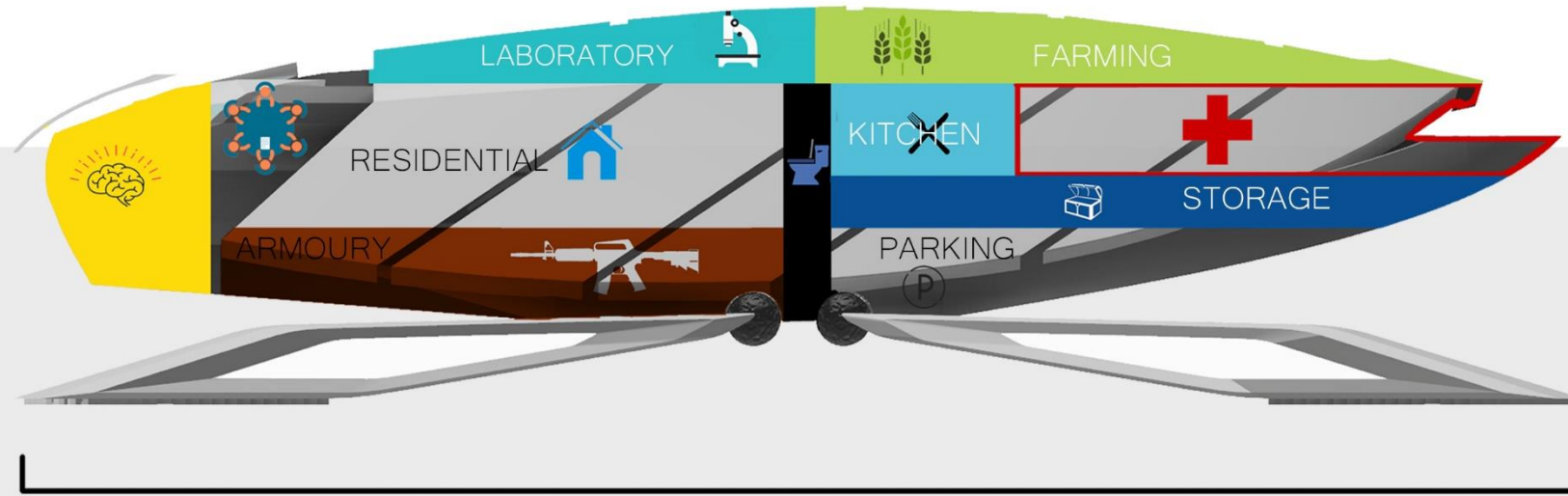

220,000 MM



90,000 MM

170,000 MM

PACKAGE

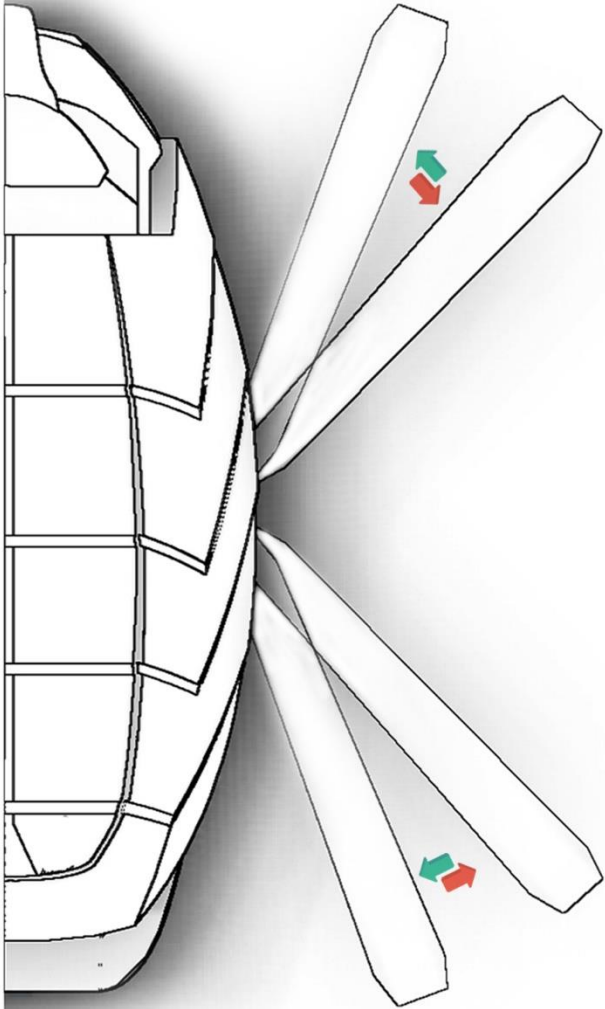

Its glids to move in following directions

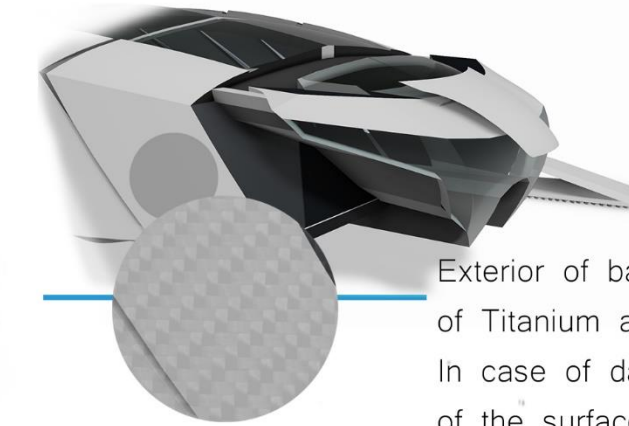

Exterior of base is built by cubes of Titanium aluminide metal. In case of damage to any side of the surface it can be replaced by a surface from any other side .

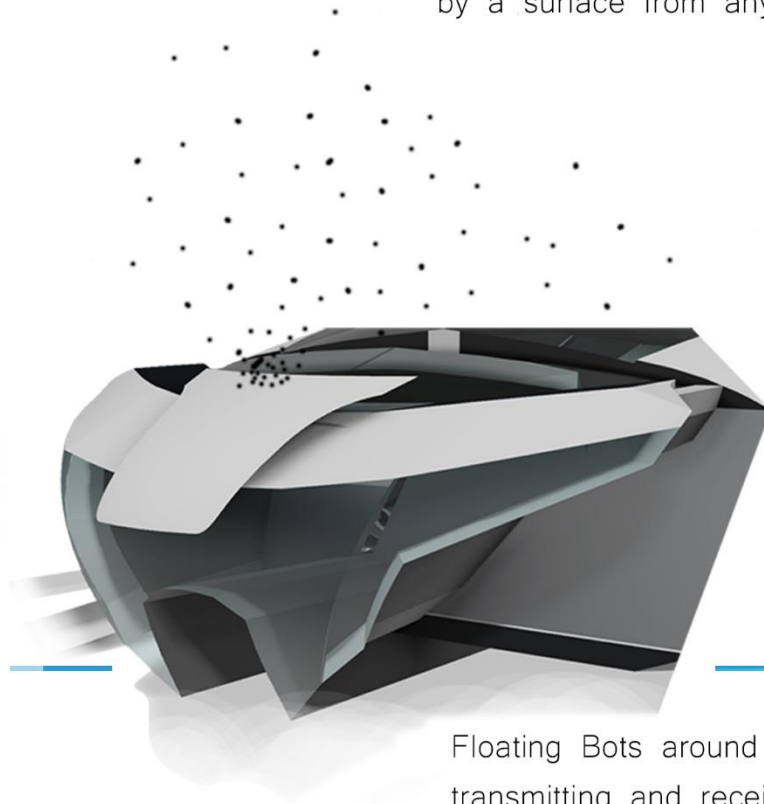

Floating Bots around the Base transmitting and receiving real time signals.

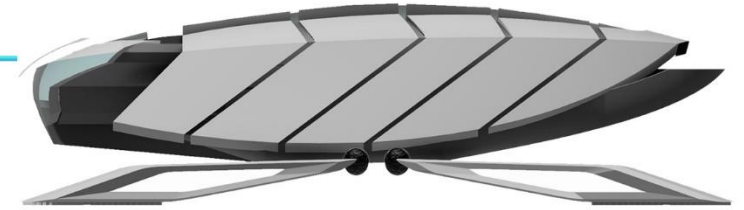

MOVING STANCE

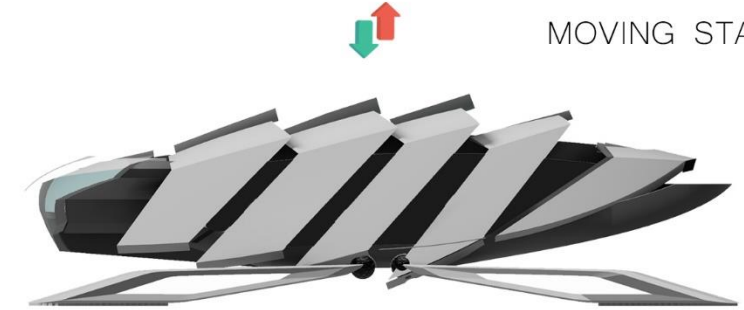

TRANSITION STANCE



GROUNDED OPERATIONAL STANCE

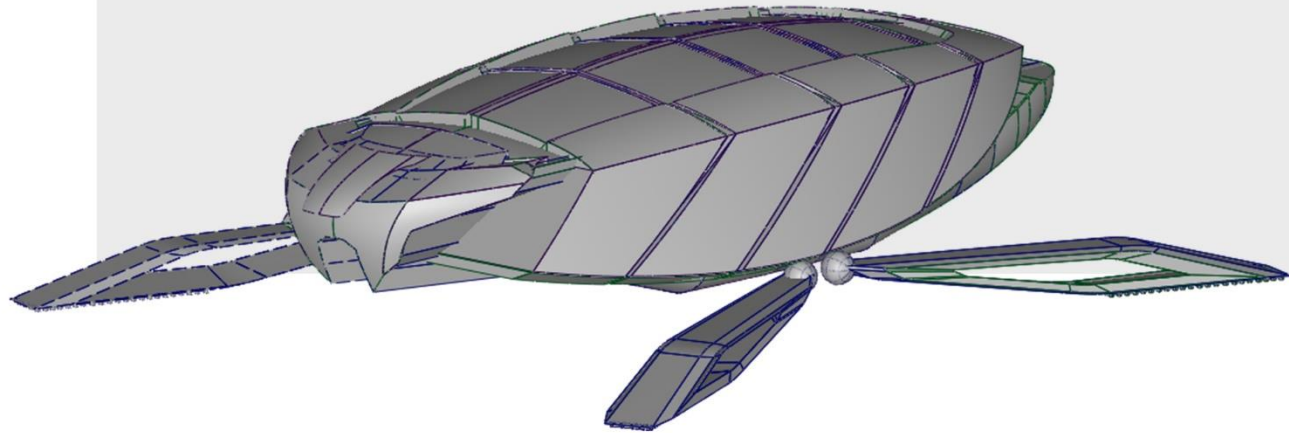
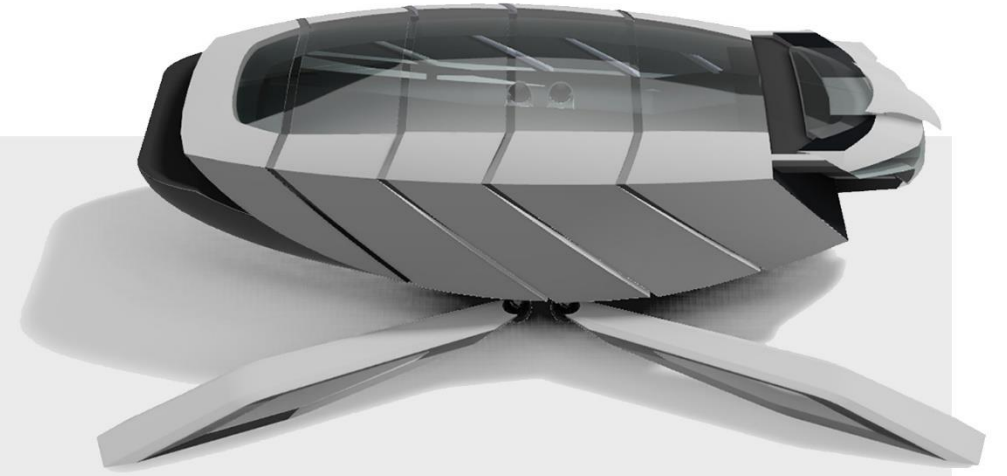
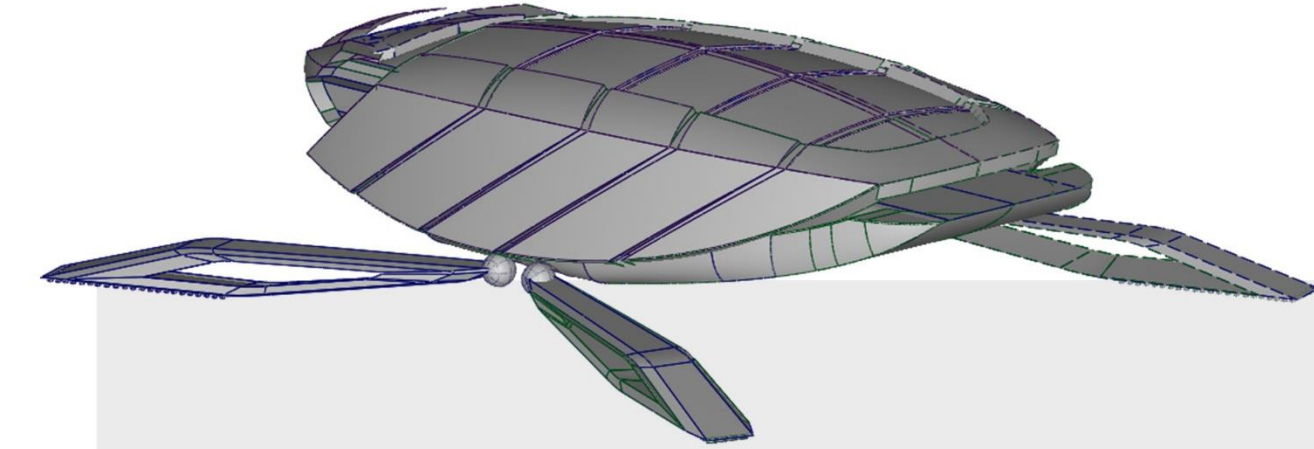

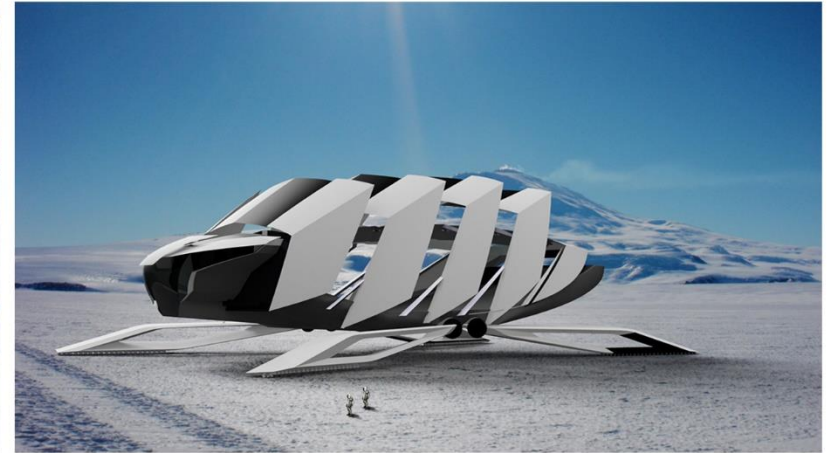
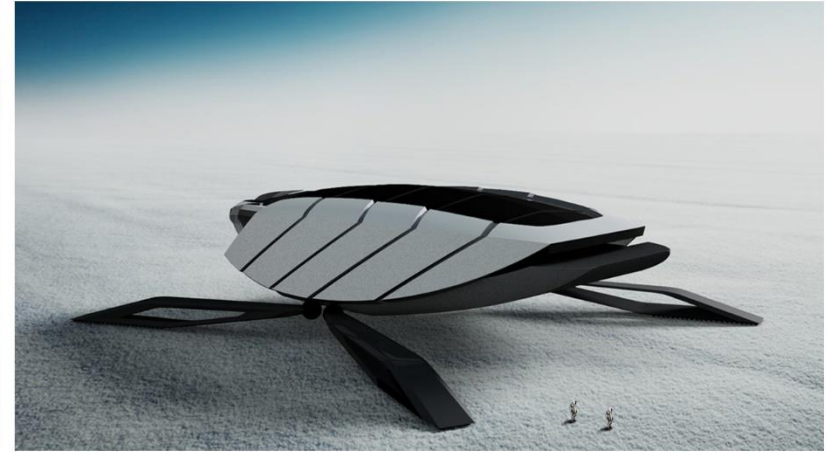

SCENARIOS

RE-LEAF

(THESIS PROJECT)

“ To design a concept used by tea garden labours to help them create better business and work in better ergonomic condition. “

BRIEF

India is the second largest producer of TEA in the world.

Tea is one of major plantation crops in India and one of the most consumed beverage 96 Lakh (9.66 million) metric tonnes of tea was produced in India in 2015.

Tea gardens are spread over 1393624.93 acres in India. Tea industry in India employe around 35 Lakh (3.5 million) people.





Female body can perform nimble task
Male body can withstand tough task

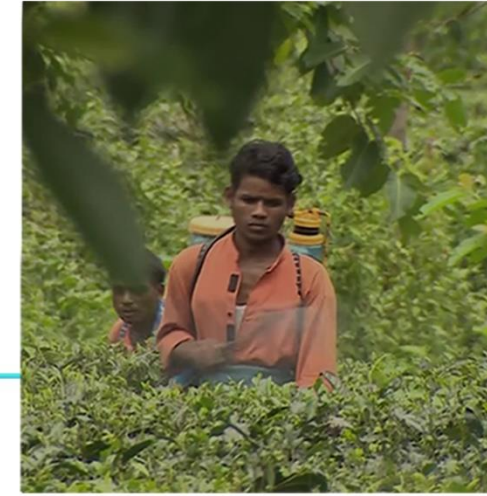

Bad ergonomic / Volume / Weight



Saving time while unloading basket.
(Walk distance to empty and walk back to plucking location)



No effective transportation system for labour in tea estate.

DIFFICULTY



AGILE / STRONG

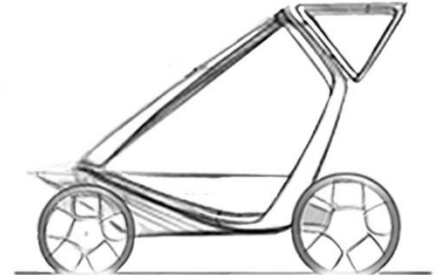

KEY SKETCH

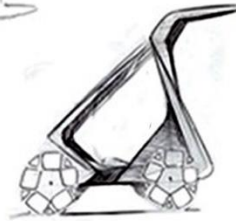
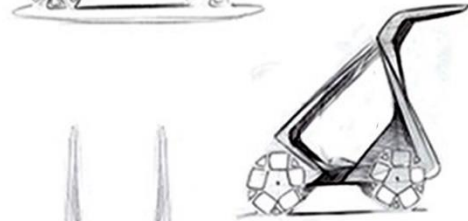

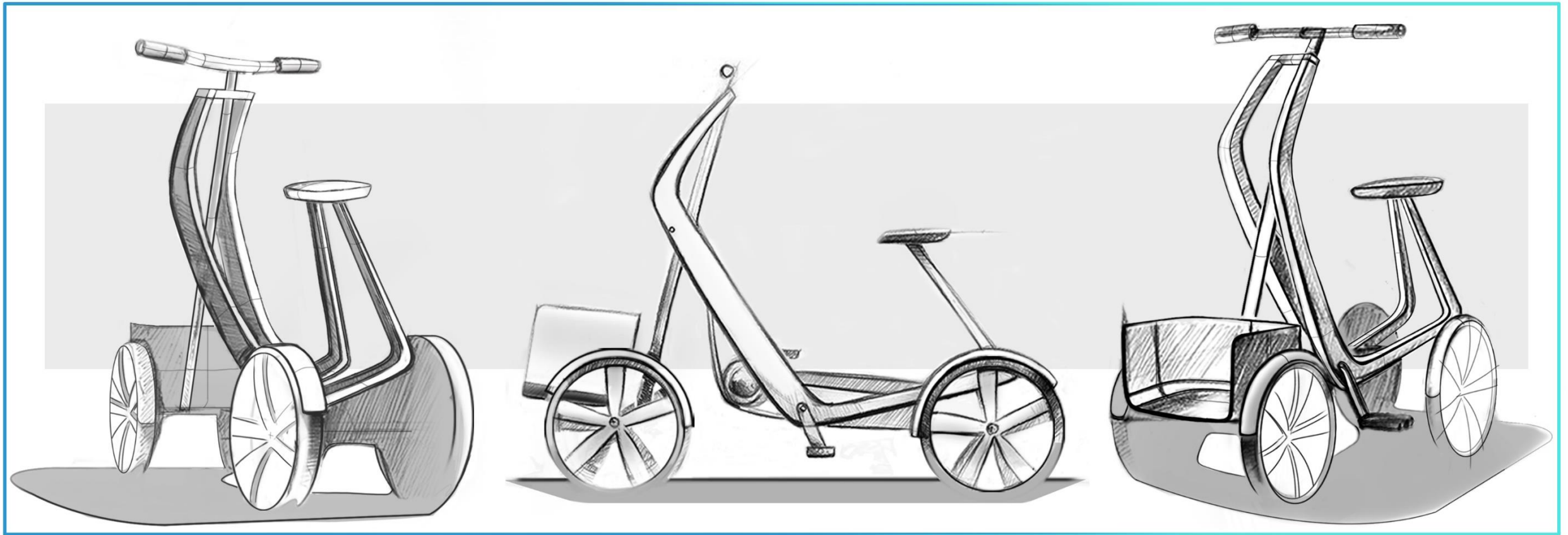
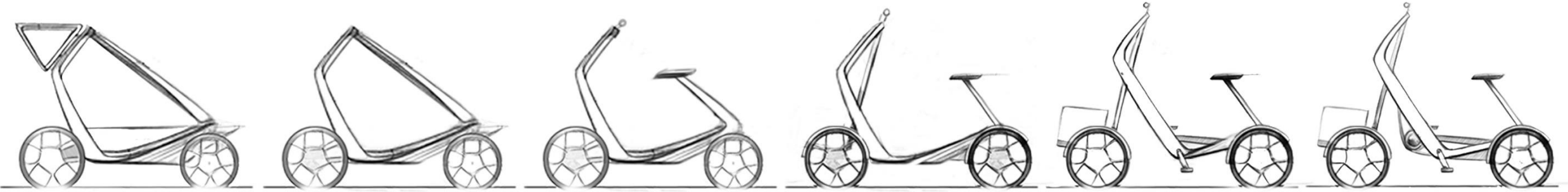

FINAL CONCEPT

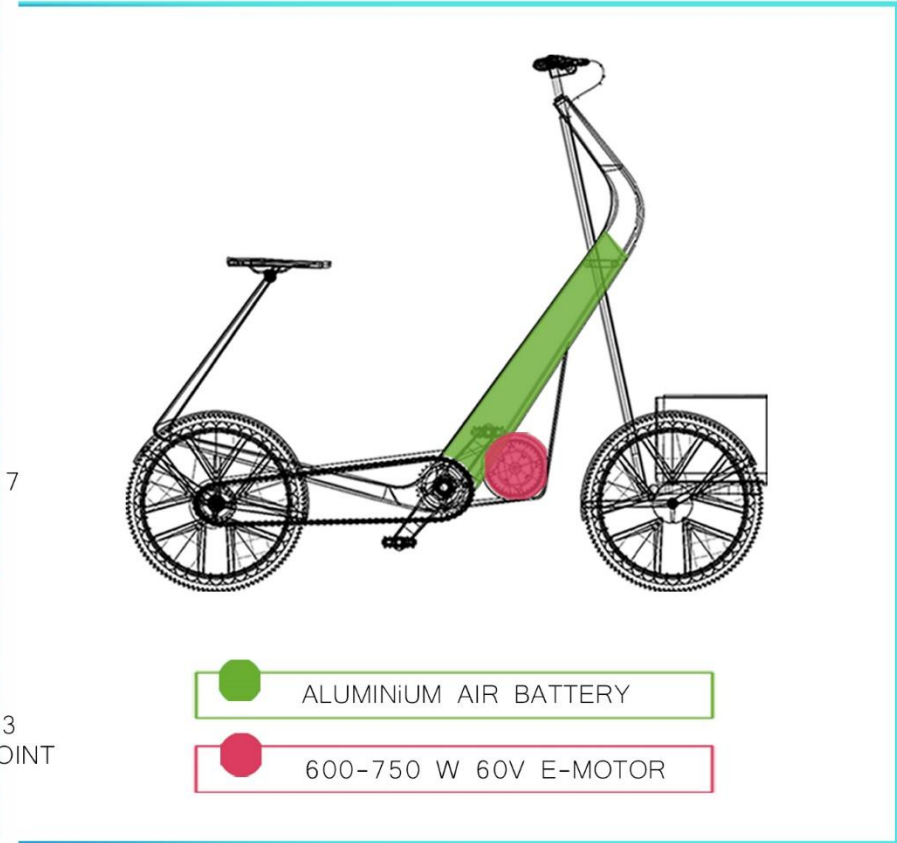
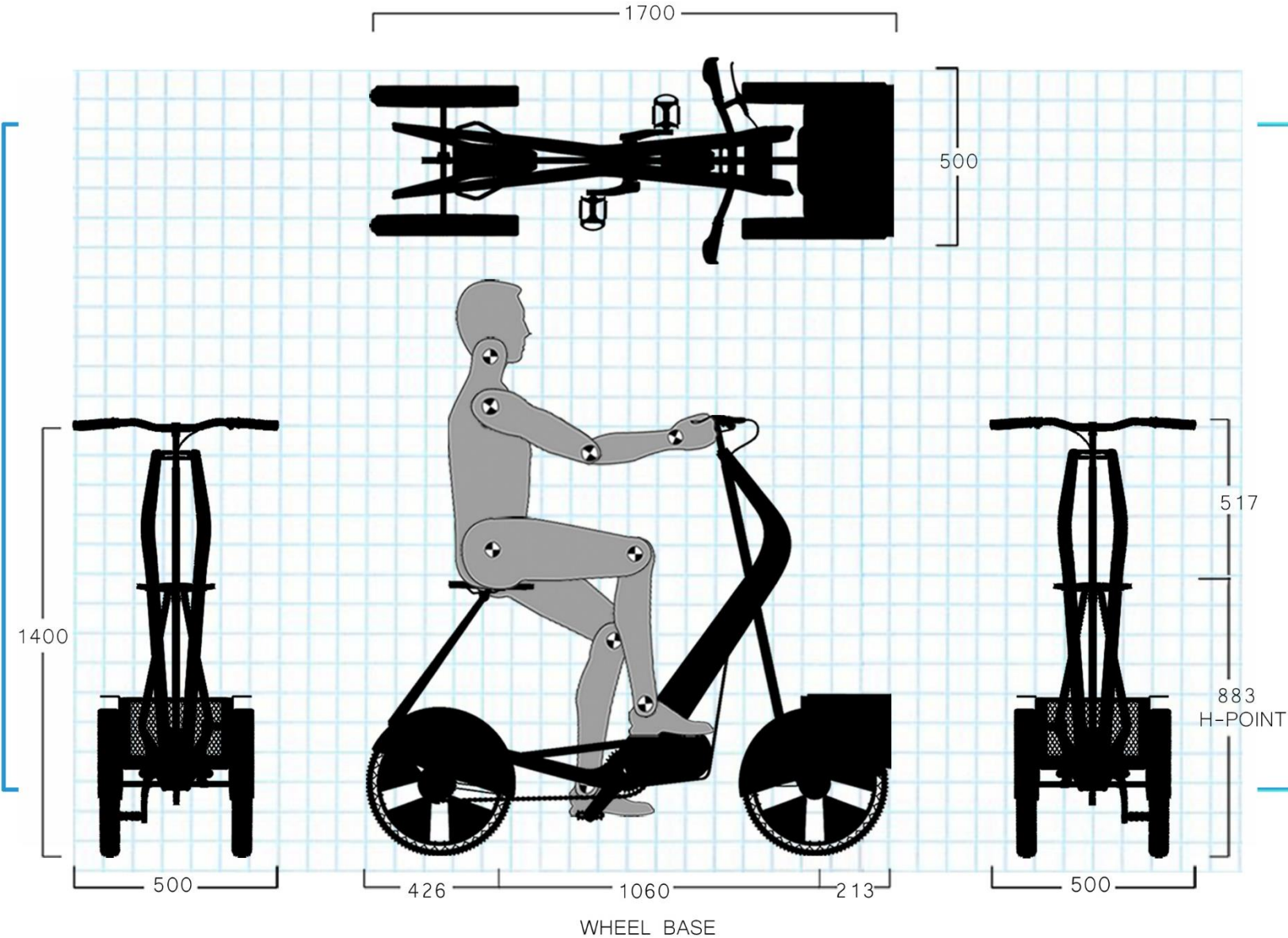

PACKAGE



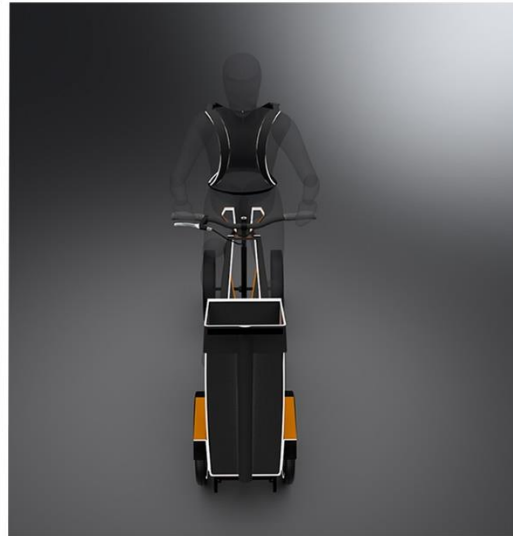

AUTODESK VRED DESIGN RENDERS

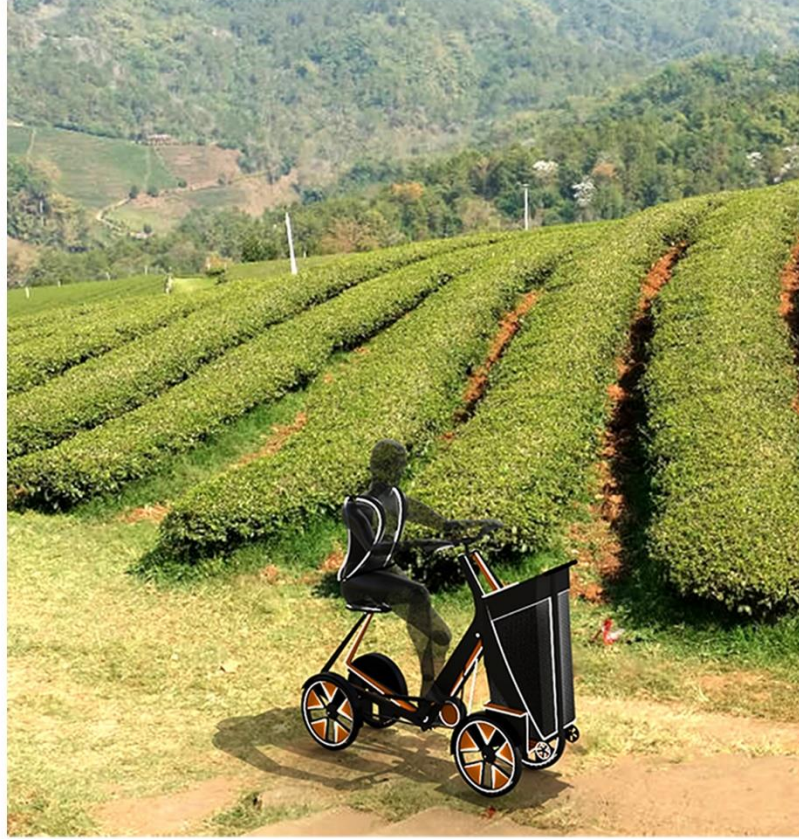

SCENARIOS

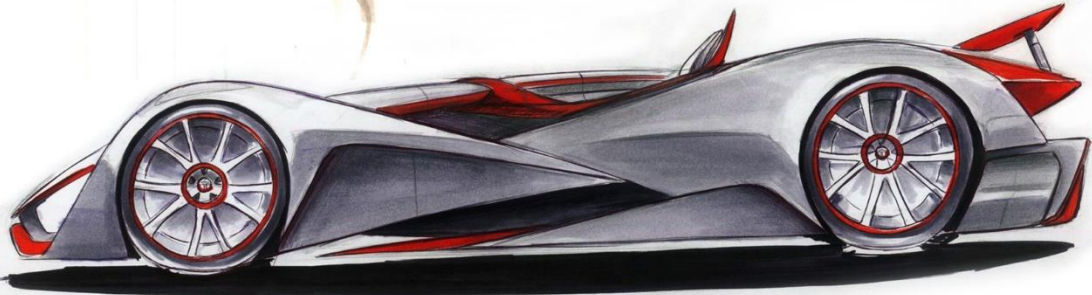
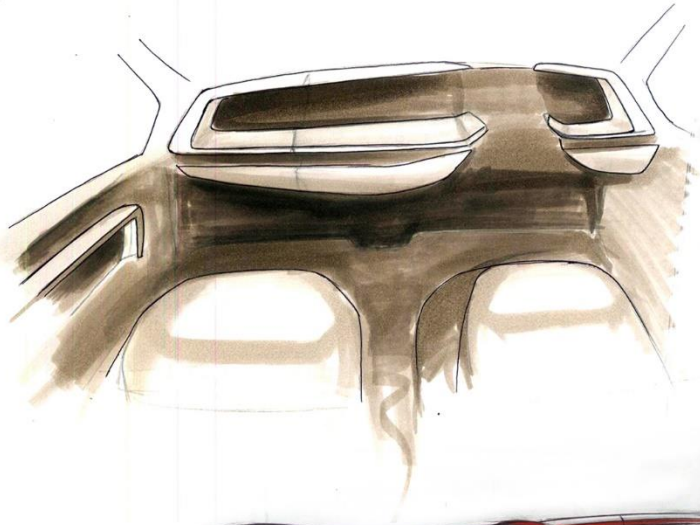
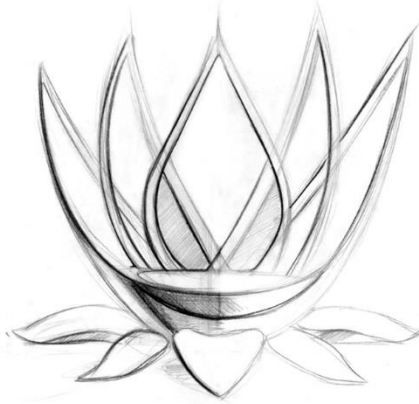
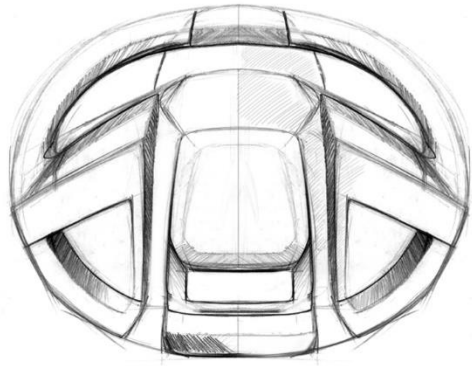
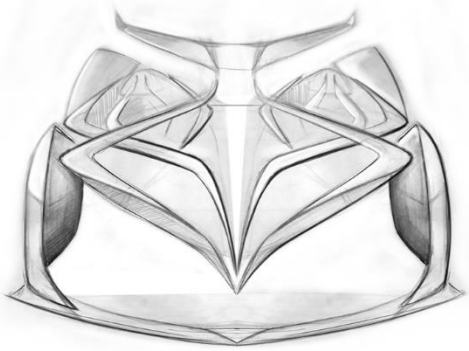

MISCELLANEOUS

+91-9545991337

abhay.ratadiya95@gmail.com



VIJAY (Victory) DEEP (Lamp)

INSPIRATION

During the Ancient times in the Aryan(Indian) culture, Queen wished the King to be victorious in the war by holding Puja Thali with a lamp otherwise know as Vijay Deep in the Indian culture symbolising blessing for the victory. Lotus shown in the background symbolises purity of the body (here it representing the brand), speech & mind. It is the National flower of India.

FRONT

BACK

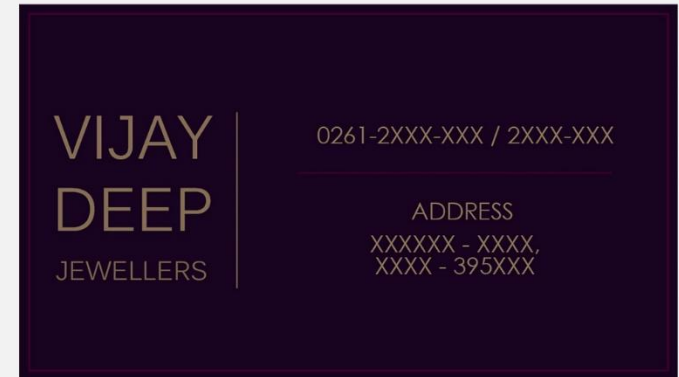

VISITING CARD

FREELANCE PROJECT (LOGO DESIGN)



AUTOMOTIVE PHOTOGRAPHY

+91-9545991337

abhay.ratadiya95@gmail.com

THANK
YOU!

CONTACT

abhay.ratadiya95@gmail.com

+91 9545991337