

HELLO
SAT SRI AKAAL
NAMASTE

Welcome to the portfolio of
19 Year Old (Sophomore)
Transportation Design
Student.

MMXVII

portfolio

“

SUCCESS
SEEMS TO BE
CONNECTED
WITH
ACTION

”



ALPHA INTRODU -CTION

panjab/pune

Harley D. | Pogonophile | Minimalist
Optimist | Nature | Food | Running
Sketching | Movies

ABOUT ME



HARKARANVIR SINGH

TRANSPORTATION DESIGNER

PROFILE

I am a 19 Year Old (Sophomore)
Transportation Design Student seeking
3-6 month Internship in the same interest.

CONTACT INFO.

Phone +(1765) 500364
Mobile +(91) 7986 150 0015
Email harkaranvirs@gmail.com
Address Gobindgarh, Punjab, India

SOCIAL MEDIA

fb.com/harkaranvir
@harkaranvir
@harkaranvir

WHAT I DO BEST



- Sketching & Rendering
- Traditional Drawing
- Graphic Design
- Photography
- Time Management
- Research and Dev.

EDUCATION & EXPERIENCE

- 2000 - 15 Om Prakash Bansal Modren School
 - Elementary Education
 - (10 + 2) Diploma Business/Commerce, General
- 2015 - 19 DYPDC Center for Automotive Research & Studies
 - Transportation Design Student
 - Created social media for daily postings
- 2015 Honor & Award • Cumulus Design Contest 2015
 - Winner of the Poster Making Competition
 - Design Work Displayed at Cumulus 2015

SKILLS

- Sketching & Rendering ●●●●●●●●
- Traditional Drawing ●●●●●●●●
- Research and Dev. ●●●●●●●●
- Graphic Design ●●●●●●●●
- Photography ●●●●●●●●
- Time Management ●●●●●●●●



Work

Something that is the number one priority and everything else is secondary, family supports me at this.



Travel

For me Travelling is the only Rejuvenation my brain and body needs & the food, incontestably.

MY PASSION PROCESS

These are the two things which inspire me the most and help me get most out of the creative individual inside.

content digest

In this Paperback you will find my developing skill of Industrial Design Work. Feel free to look around and if you like what you see, get in touch. Your advice & thoughts are welcomed.

01

Form from Nature

Derive a form which is either inspired by nature or derived from it.

02

Intense Pulse Light

Re-Design Laser Hair Removal Device for Phillips – Philips Lumea

03

Fluidic W. Mouse

One day Product Design workshop, wireless mouse (Unbranded)

04

Interior Re-furbish

One Week Interior Re-Design Project for Volkswagen Polo 2014.

05

Mini Project - I & II

Outright Re-design (Exterior & Interior) for The BMW CSL 3.0

06

Depiction book

Including free time sketches, illustrations & Digital Renders.

coccin -ellidae

form inspired by
nature, derived from

I chose a Lady beetle to evolve a form which
is inspired from it, in an attempt to make it
look innate, clean & pure

Sketches + Renderings + Miniature



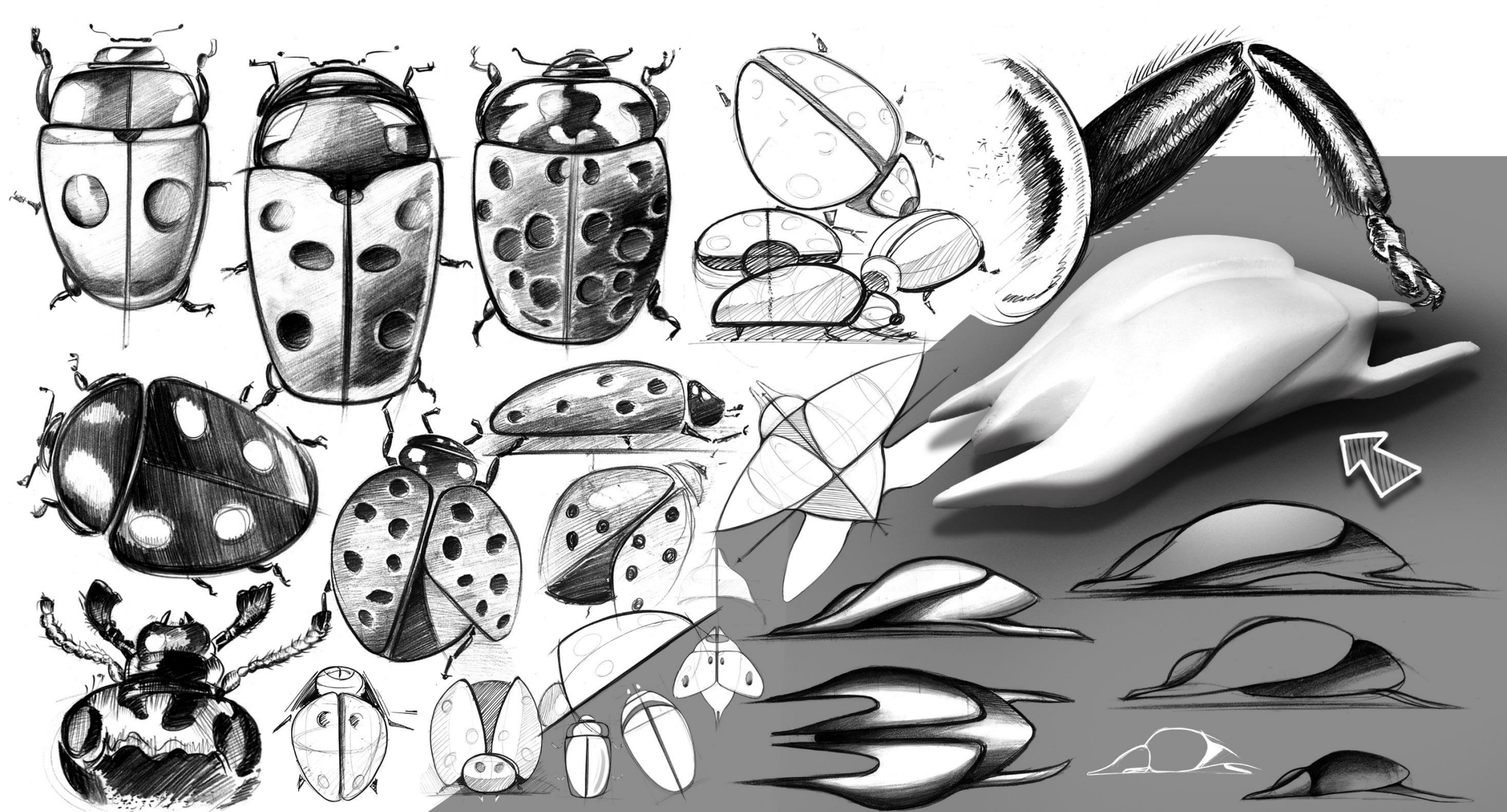

PHILIPS IPL

PHILIPS LUMEA



INTENSE PULSE

Different energies, pulse durations, and wavelengths of light to strategically work on the skin.



CORDLESS

The unique cordless design is perfect for treating the areas you want, when you want.

ABOUT LUMEA

Philips Lumea IPL hair removal system is a cordless hair removal tool that uses Intense Pulsed Light technology to prevent hair growth. This handy hair removal device emits gentle pulses of light that are applied to the hair root, which causes the hair follicle to go into a resting phase.

The brief was to re-design an existing product & change its aesthetic value which exists in the market, although it is an expensive product but doesn't really look like one.

Hair falls out naturally
with **regrowth prevented**

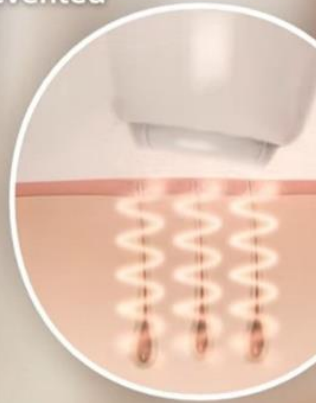

lasers & devices

Lasers can be used for a variety of aesthetic purposes. The word 'Laser' is an acronym for "Light Amplification by Stimulated Emission of Radiation."

- Skin resurfacing
- Tightening
- Fat reduction
- [Hair removal](#)
- Vascular lesions
- Pigmentation
- Acne-causing bacteria
- Blood vessels

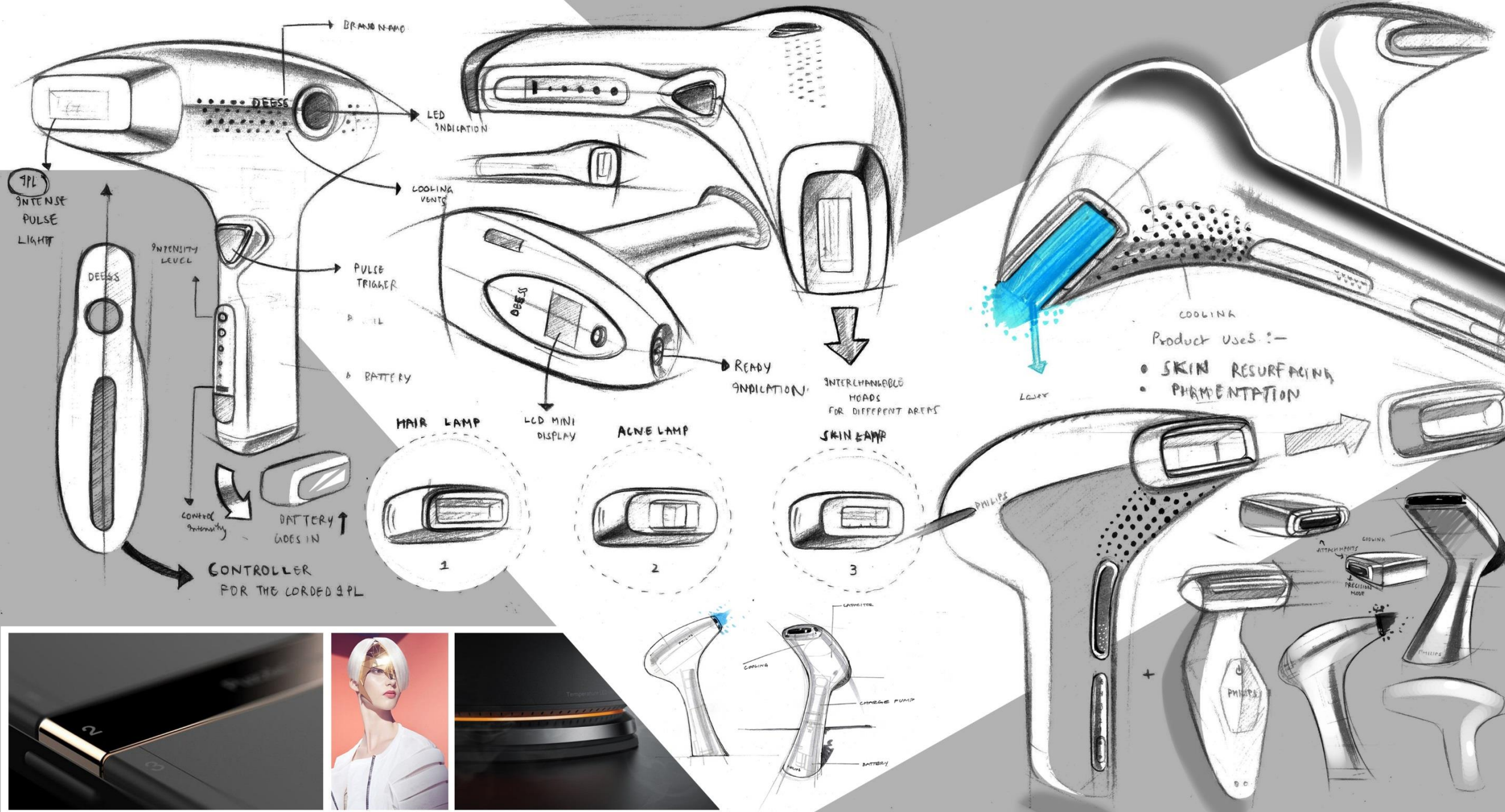

9PL
INTENSE
PULSE
LIGHT

INTENSITY
LEVEL

CONTROL
INTENSITY

BATTERY
GOES IN

CONTROLLER
FOR THE CORDLESS PPL

BRAND NAME

DEESS

LED
INDICATION

COOLING
VENTS

PULSE
TRIGGER

B CELL

BATTERY

READY
INDICATION

INTERCHANGEABLE
HEADS
FOR DIFFERENT AREAS

HAIR LAMP

LCD MINI
DISPLAY

ACNE LAMP

SKIN LAMP

1

2

3

COOLING
Product uses :-
• SKIN RESURFACING
• PHOTOREJUVENATION

PHILIPS

ATTACHMENTS

COOLING
&
PRECISION
MODE

COOLING
LASER
CHARGING PUMP
BATTERY

IDEATIONS & REFINEMENT

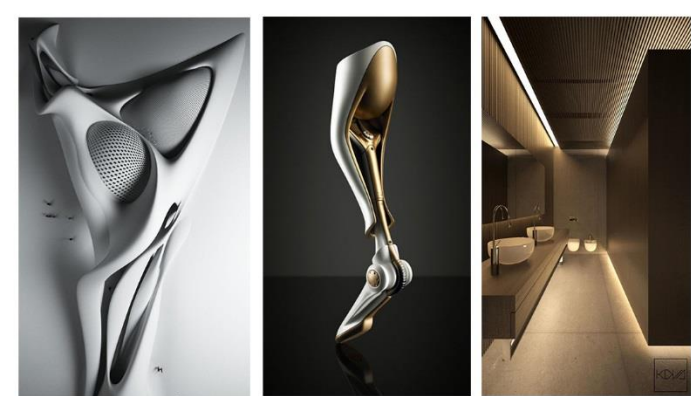

LIVE GEOMETRY

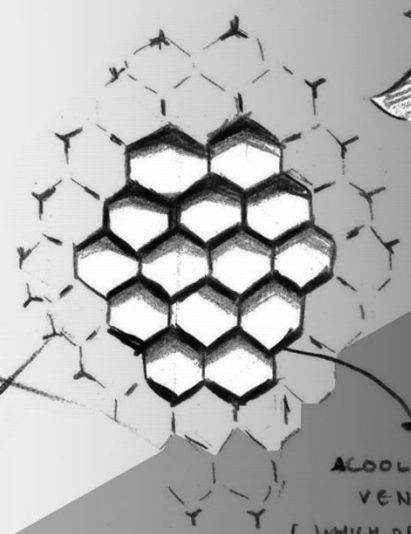

COOLING VENTS
(WHICH OPENS ONLY
WHEN NECESSARY)

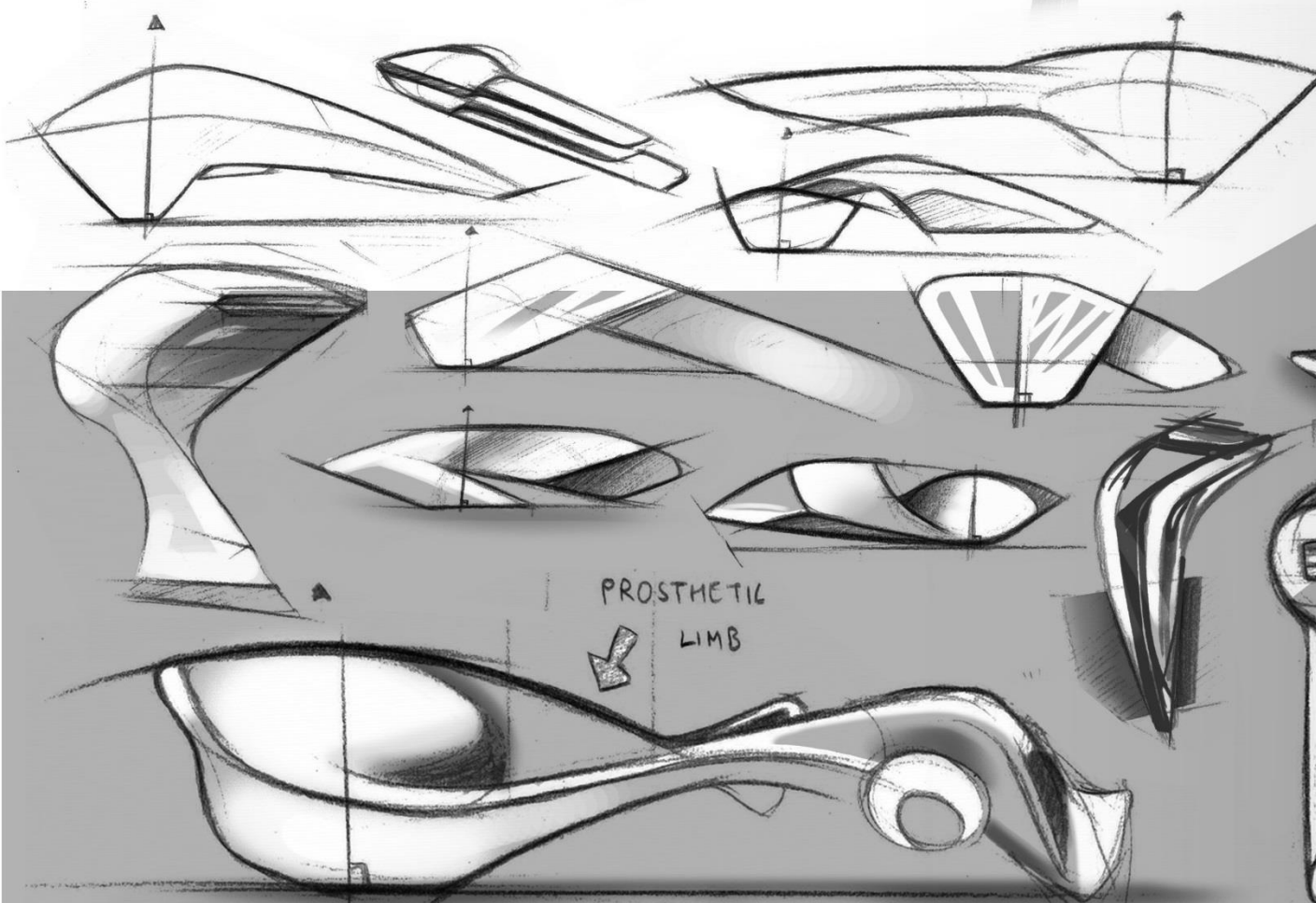

PROSTHETIC
LIMB

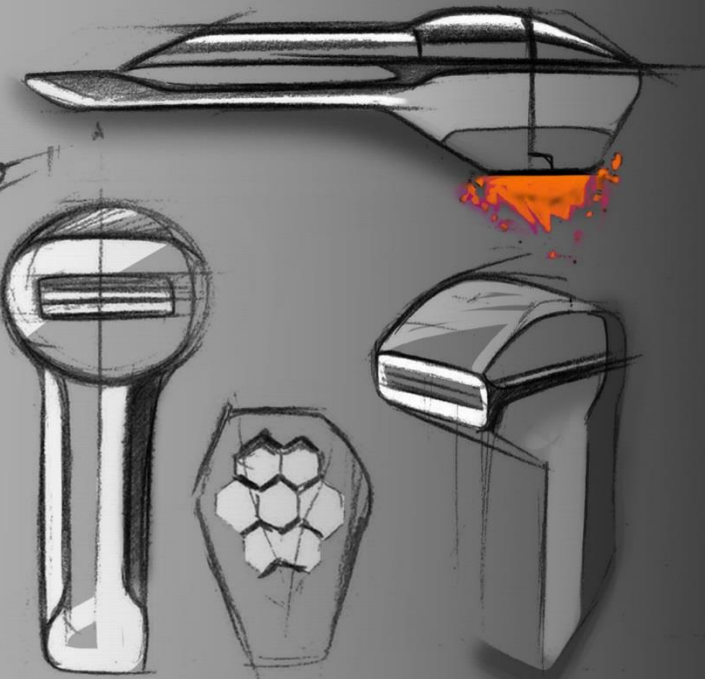



Fusion 360

mouse

fluidic wireless computer mouse

3D MODEL

ONE DAY WORKSHOP



DIGITAL MODEL RENDERINGS

VW POLO

In this [Interior Re-Design](#) project we were supposed to conceptualize a new face for the interiors of the existing Polo, the Process Includes Observing, finding difficulties, taking notes, solve the difficulties faced, Ideating, Key Sketches & Final Marker Renders.



01

quick ideations

I've tried to keep the essence of the Volkswagen Design alive as they tremendously use each and every imaginary line flowing in the interiors, every line is precisely curated and is put up in correlation.

02

final render

According to the brief we had to do 2 final marker renders from different perspectives, to understand the concept more clearly and easily.

FLOATING
DASH PANEL

PANEL
SEPERATED
FROM DASHBOARD

NEW BEATUP

FLOATING
ENTERTAINMENT
SYSTEM
PANEL

FIXED
PANEL

ASYMMETRICAL

VOLKSWAGEN
POLO TAILLAMP
INSPIRED

TILTED INWARDS
FOR MORE ENAGING
EXPERIENCE

SPORTY
CHARACTER

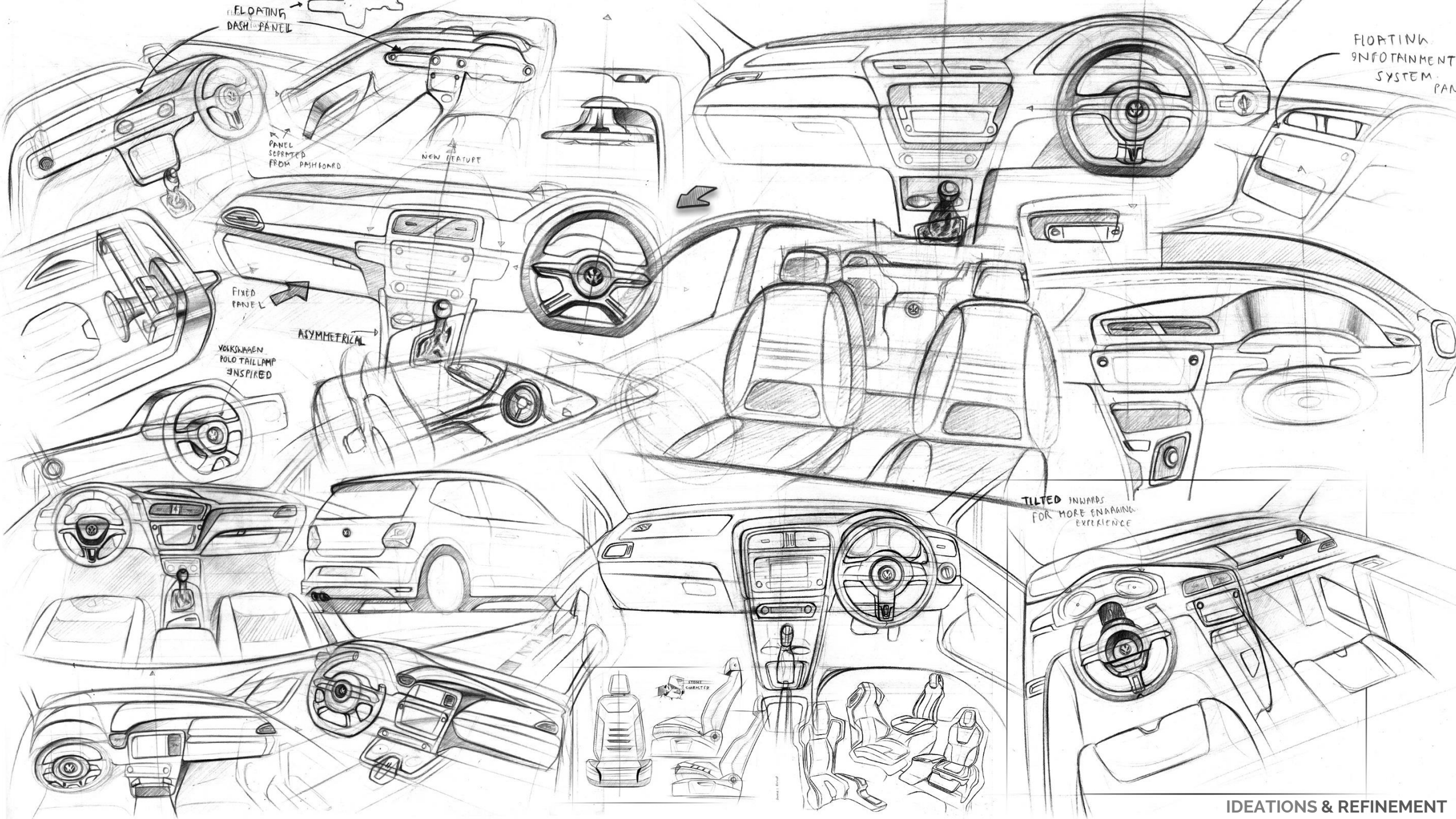

mini project

BMW CSL 3.0

Introduced in May 1972, homologation special built to make the car eligible for racing in the European Touring Car Championship. 1,265 were built in total

The 'L' in the designation means leicht, The lightness was achieved by using thinner steel to build the unit body, deleting the trim and soundproofing, using aluminium alloy doors, bonnet, and boot lid.

Exterior – One Month

Interior – Two Week





2025

RE-DESIGNING OUTRIGHT

BMW CSL 3.0's Re-design for the year 2025 as the brand has planned to launch a 50th Year anniversary Edition, BMW's i-division has planned to unveil a plug-in hybrid performance special one off-in 2025 with admixture of the two Marques; BMW Motorsport & BMW i.

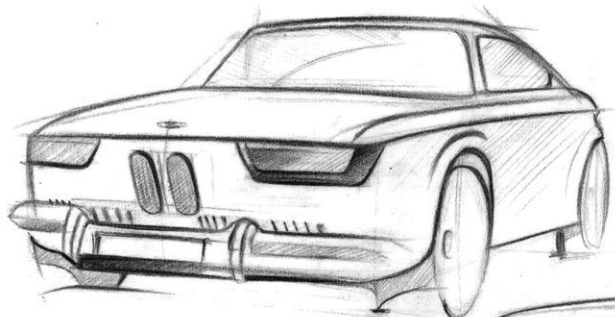

BMW 2000CS (E120) DEC 1965

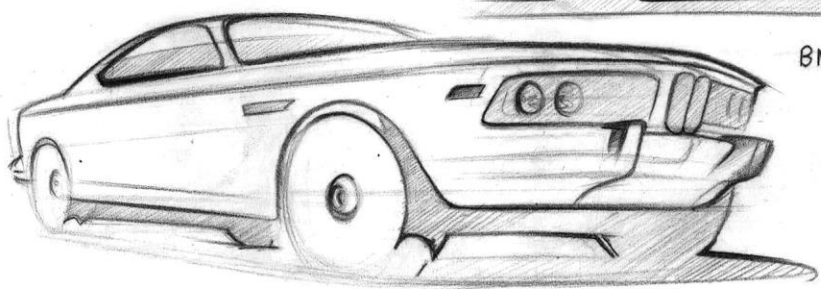
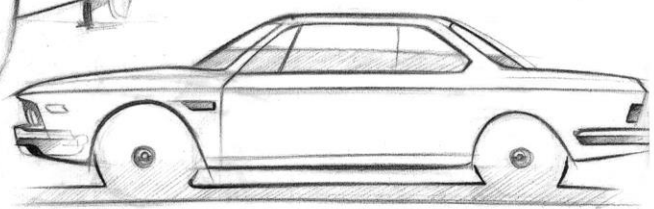

BMW 3.0CS DEC 1968

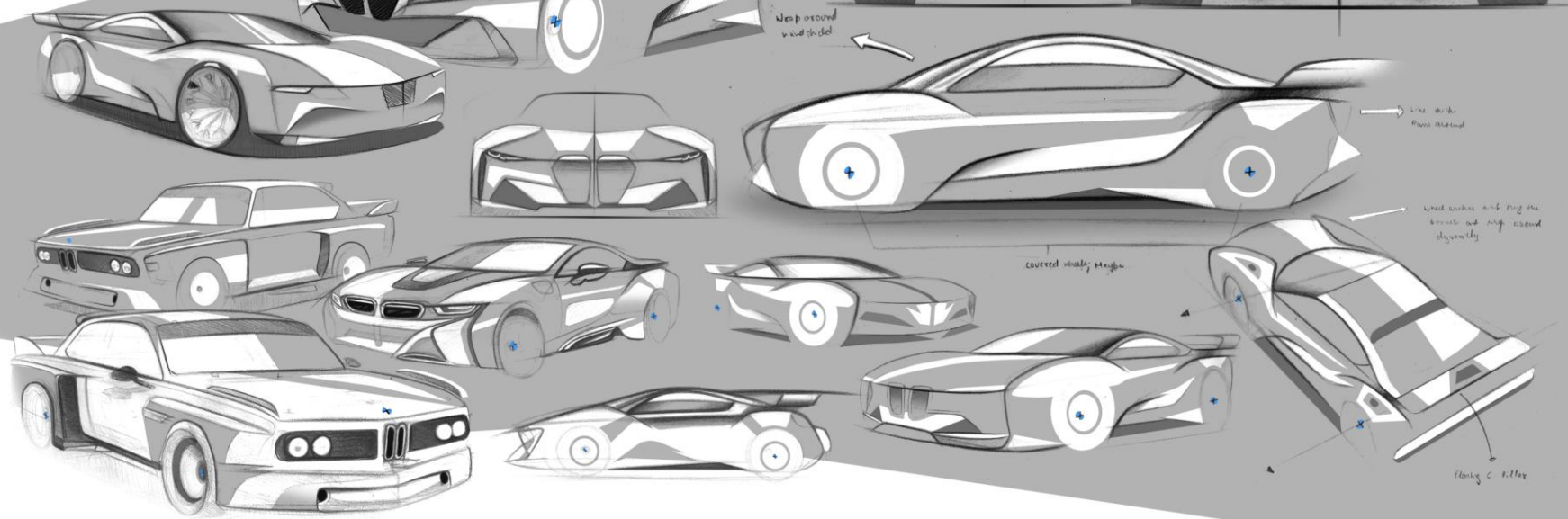
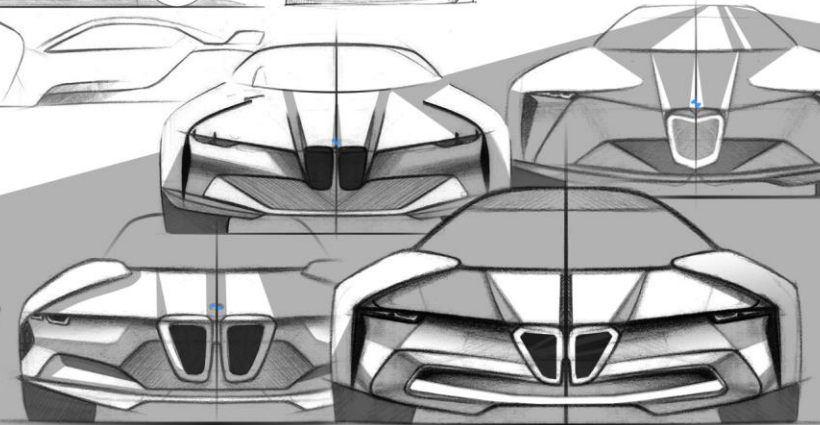
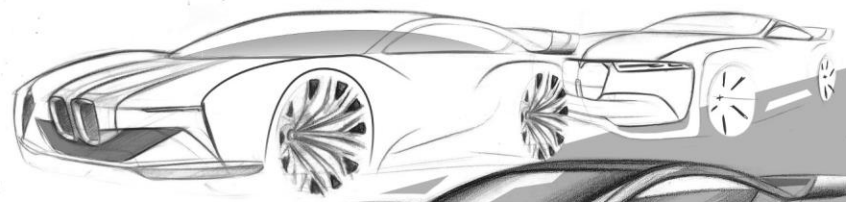
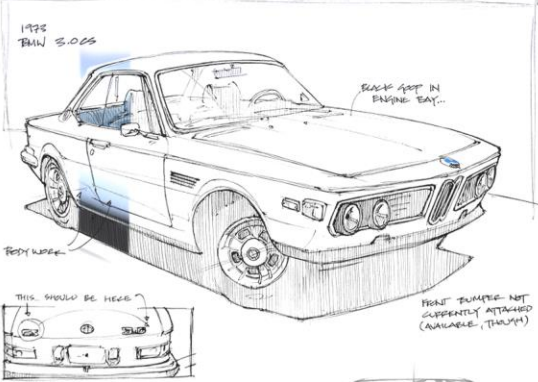
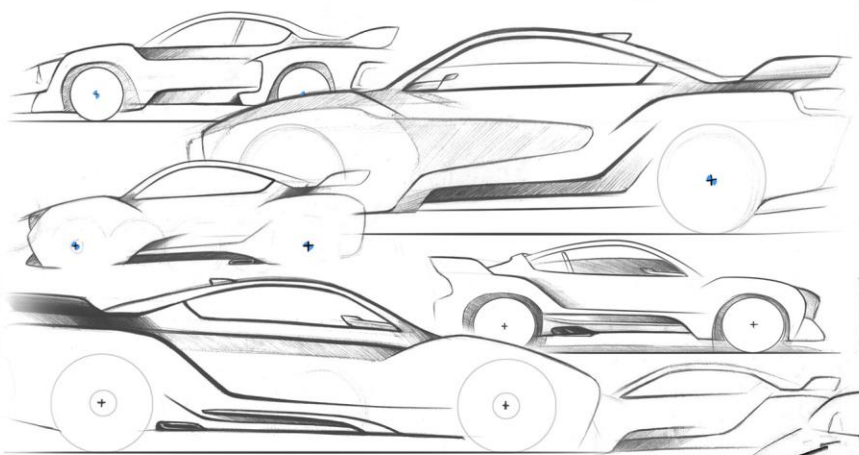

IDEATIONS (FRONT & SIDE)

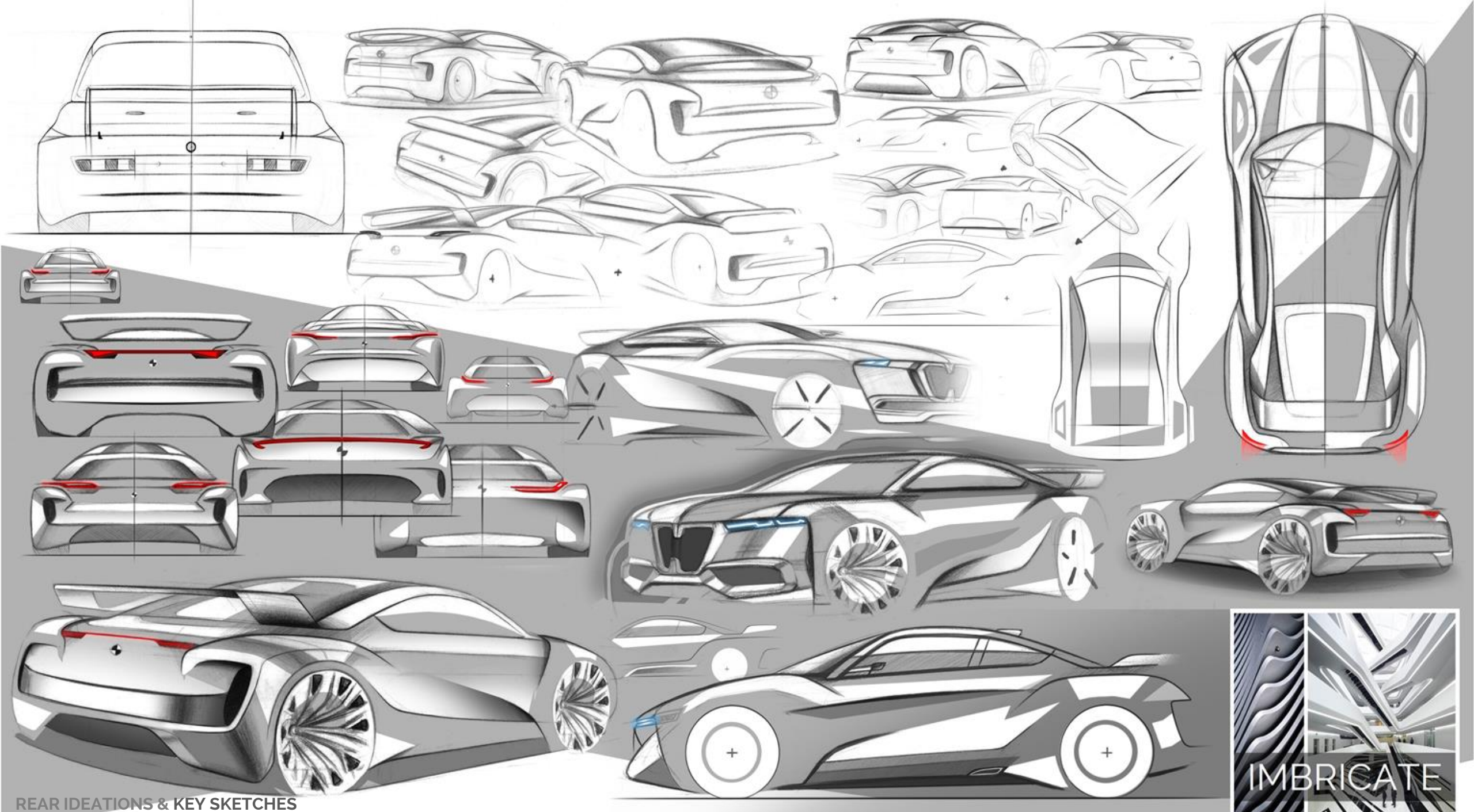

IMBRICATE

REAR IDEATIONS & KEY SKETCHES



BMW CS 3.0 e9

MOTORSPORT PRELUDE

built for BMW by Karmann

EXTERIOR

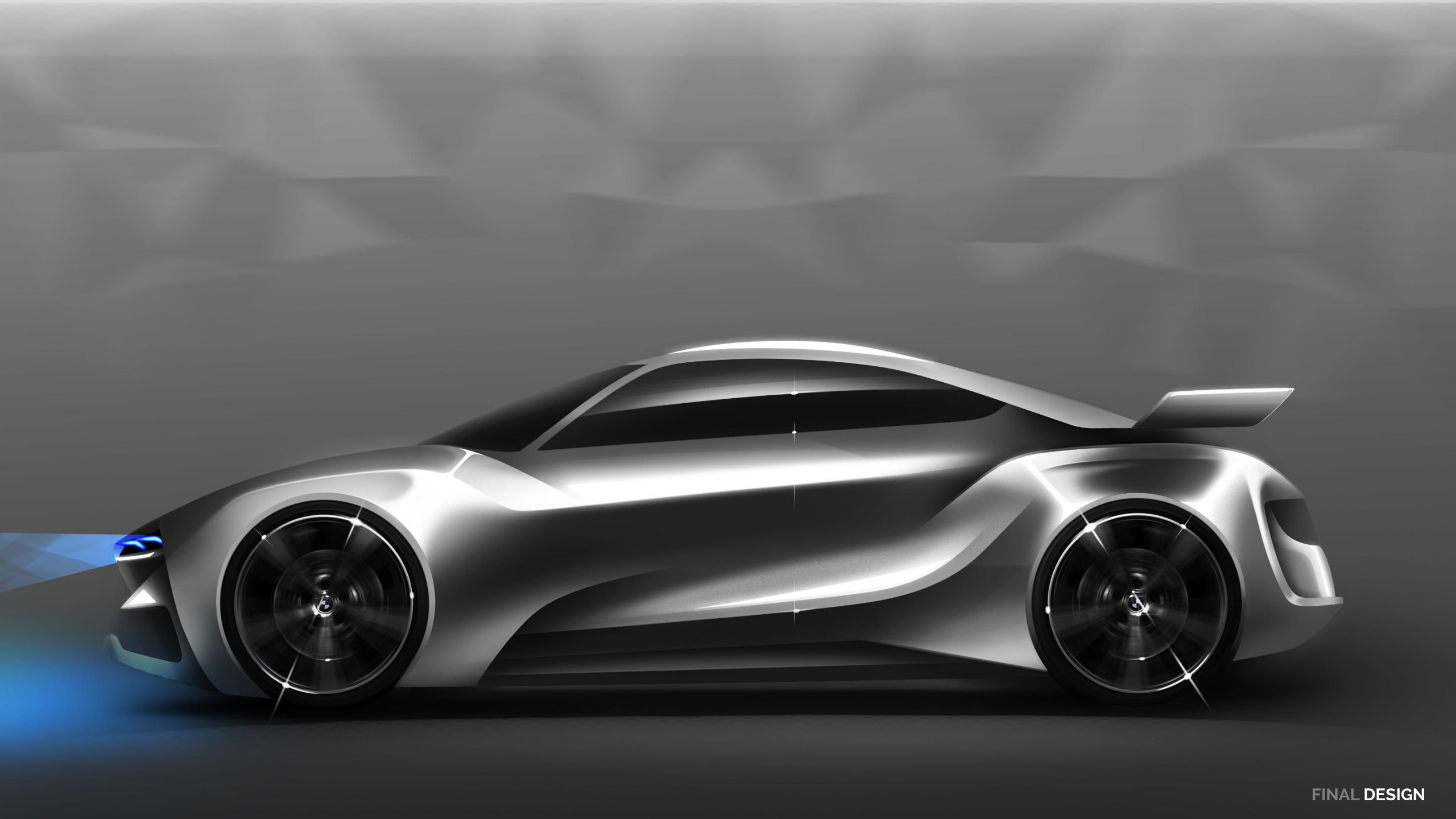

FINAL DESIGN

RE - DESIGN

The Brief was to completely redesign the car Outright (Inside Out). My main focus was to make the interiors completely in contrast to the exterior. My depiction of the interior is somewhat an abstract version of the original BMW CSL 1975. I've tried to keep the existing elements such as wooden panel and the 3 Spoke Steering Wheel.



INTERIORS

DIFFERENT DIRECTIONS

worked on & finalized the 3rd One



Direction 1

Inspired from one of the random explorations I did for the start. This form has a hollow surface with an idea of weight reduction to get a race car feel inside. Wooden texture used to give the sense of retro touch to the re-design.



Direction 2

Inspired from sketching out the existing products on the market. We tried to sketch the product, then get an abstract shape of the product overall and try to get the details to fit in right.



Direction 3

Inspired from a very pure and clean form, this is the direction which was finalized and I have tried to refine it more along with the component ideations, few marker render explorations & final Photoshop render.

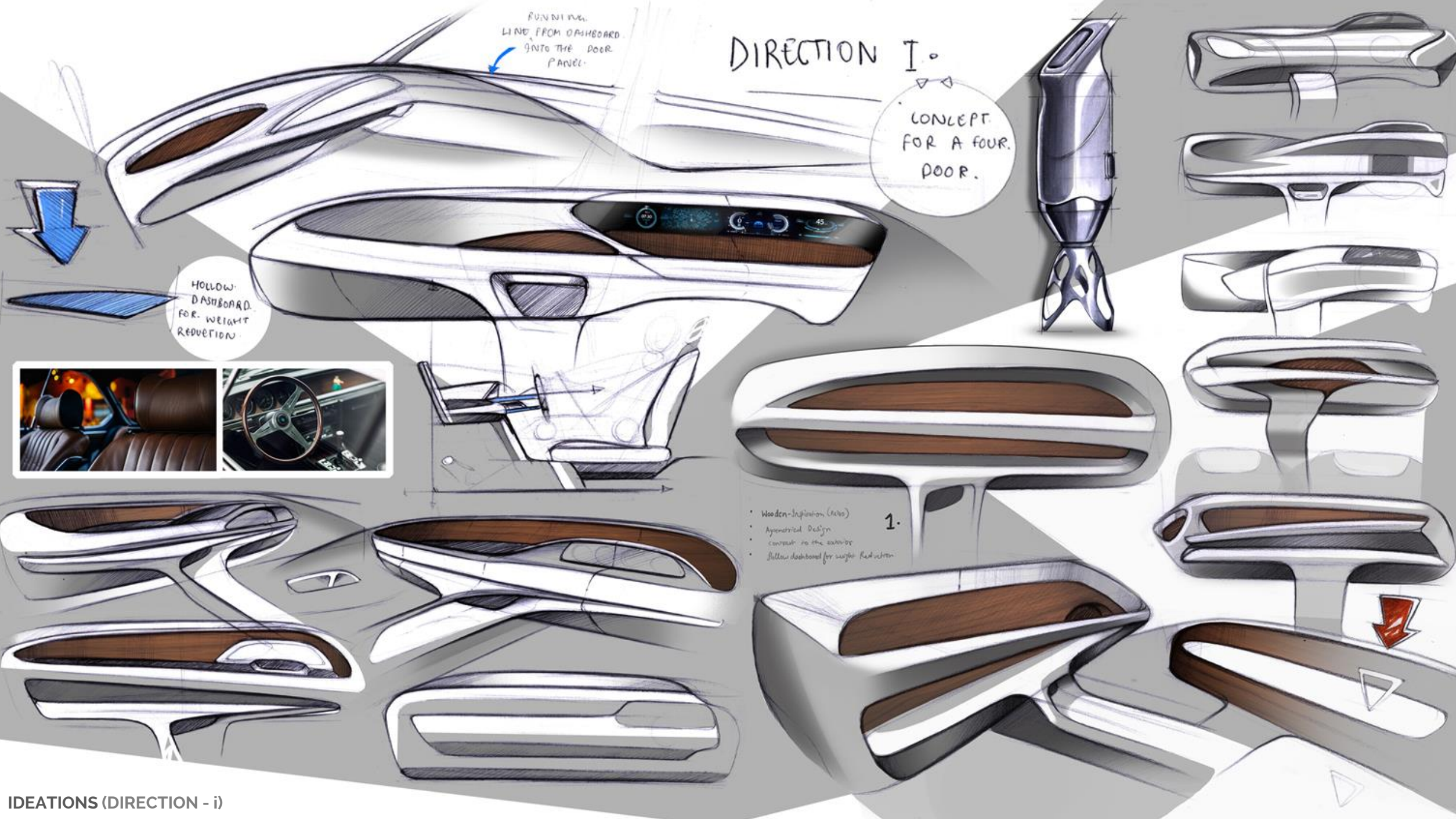

RUNNING LINE FROM DASHBOARD INTO THE DOOR PANEL.

DIRECTION I.

CONCEPT FOR A FOUR DOOR.

HOLLOW DASHBOARD FOR WEIGHT REDUCTION.

- Wooden-Inspired (New)
- Asymmetrical Design contrast to the exterior
- Hollow dashboard for weight reduction

1.

DIRECTION - II

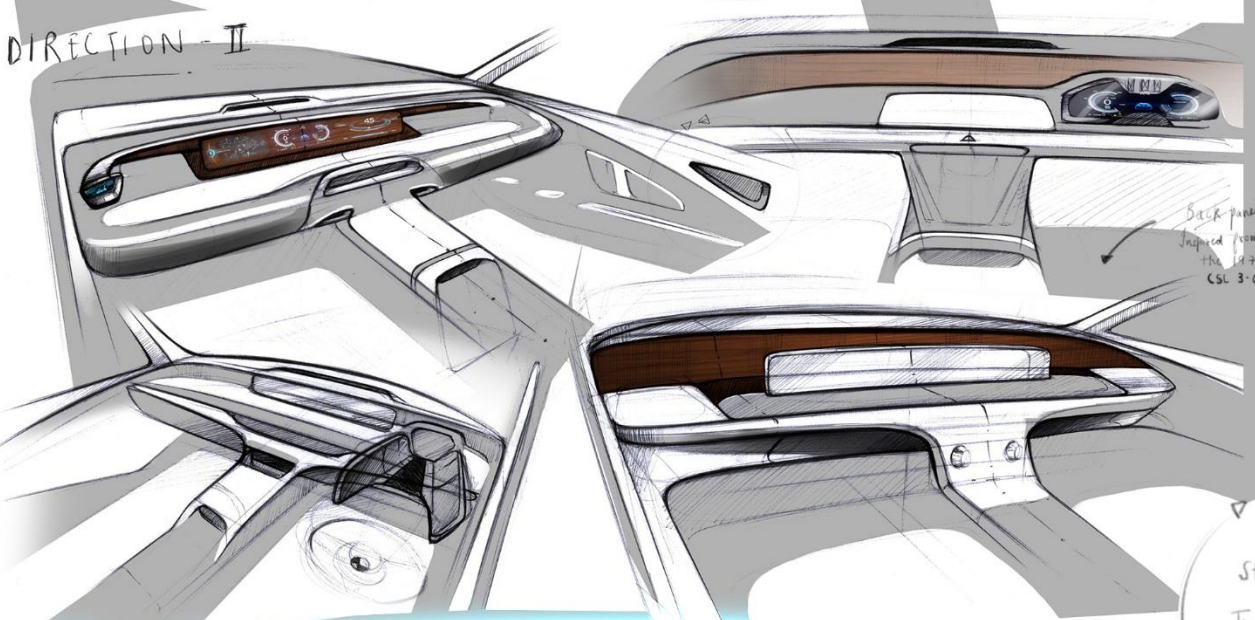

Back panel
Inspired from
the 147T
CSL 3-0

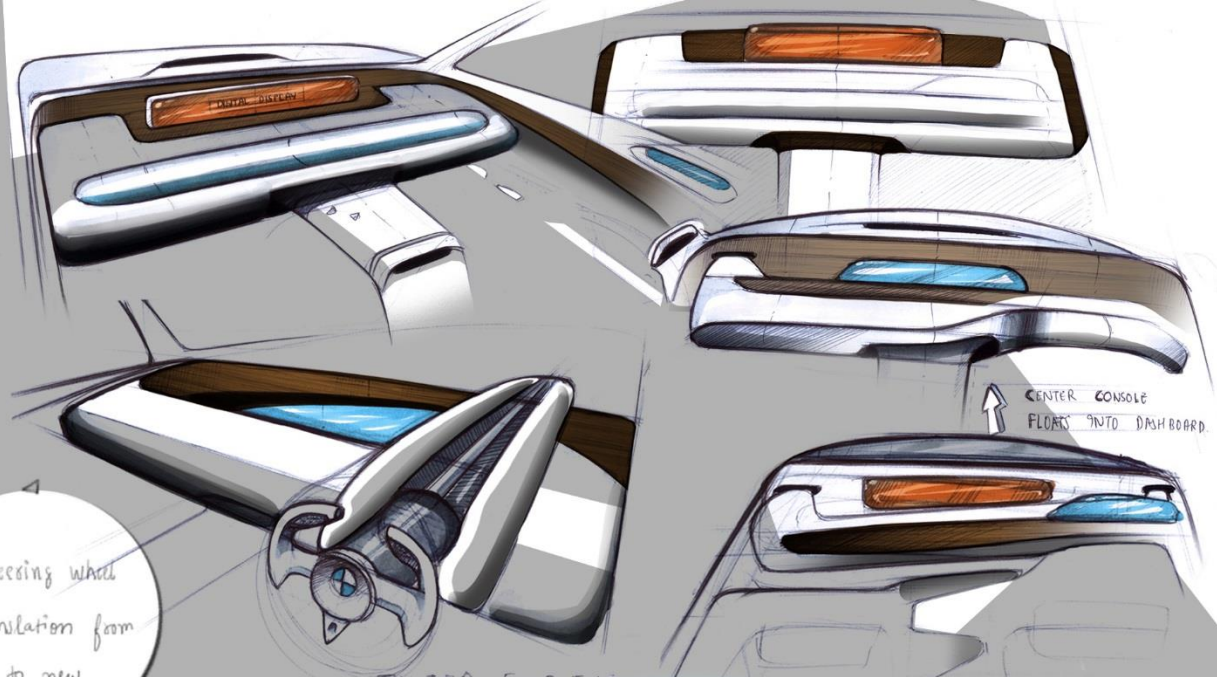

CENTER CONSOLE
FLOOR INTO DASH BOARD

Steering wheel
Translation from
old to new

TILTED FOR THE
DRIVER

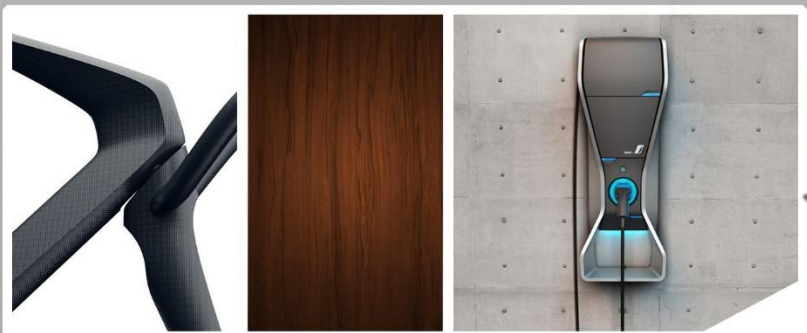
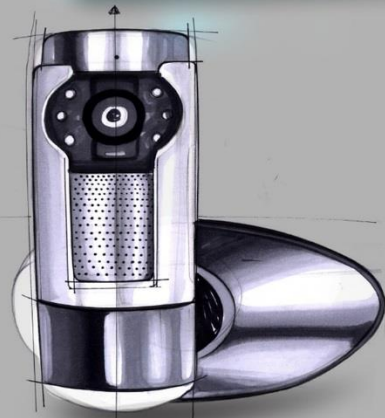
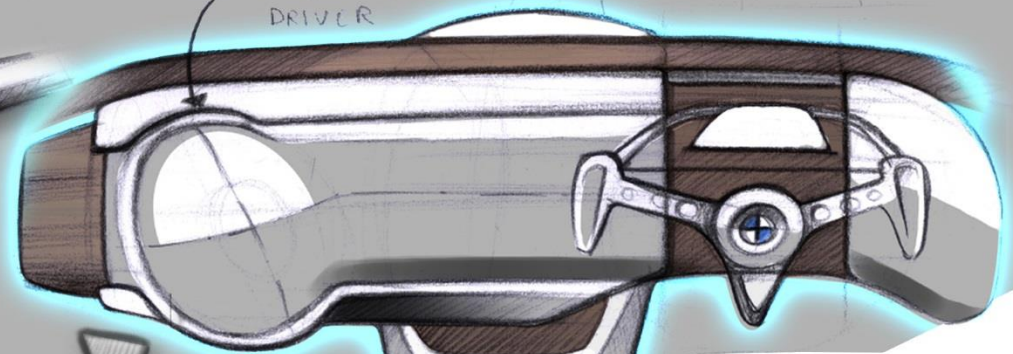
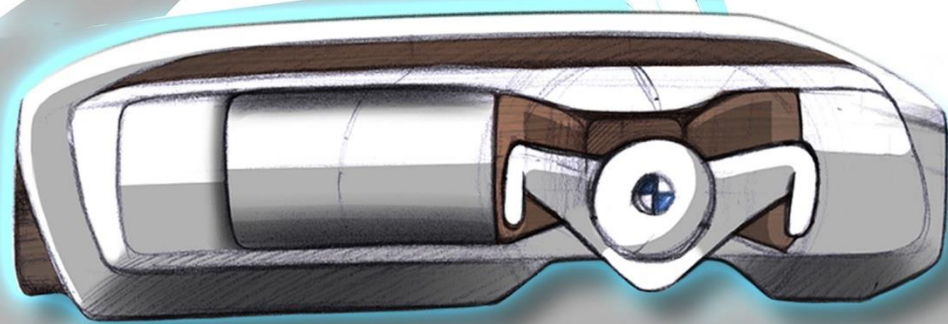

Inspiration Board
See: pinterest



DIRECTION - III .

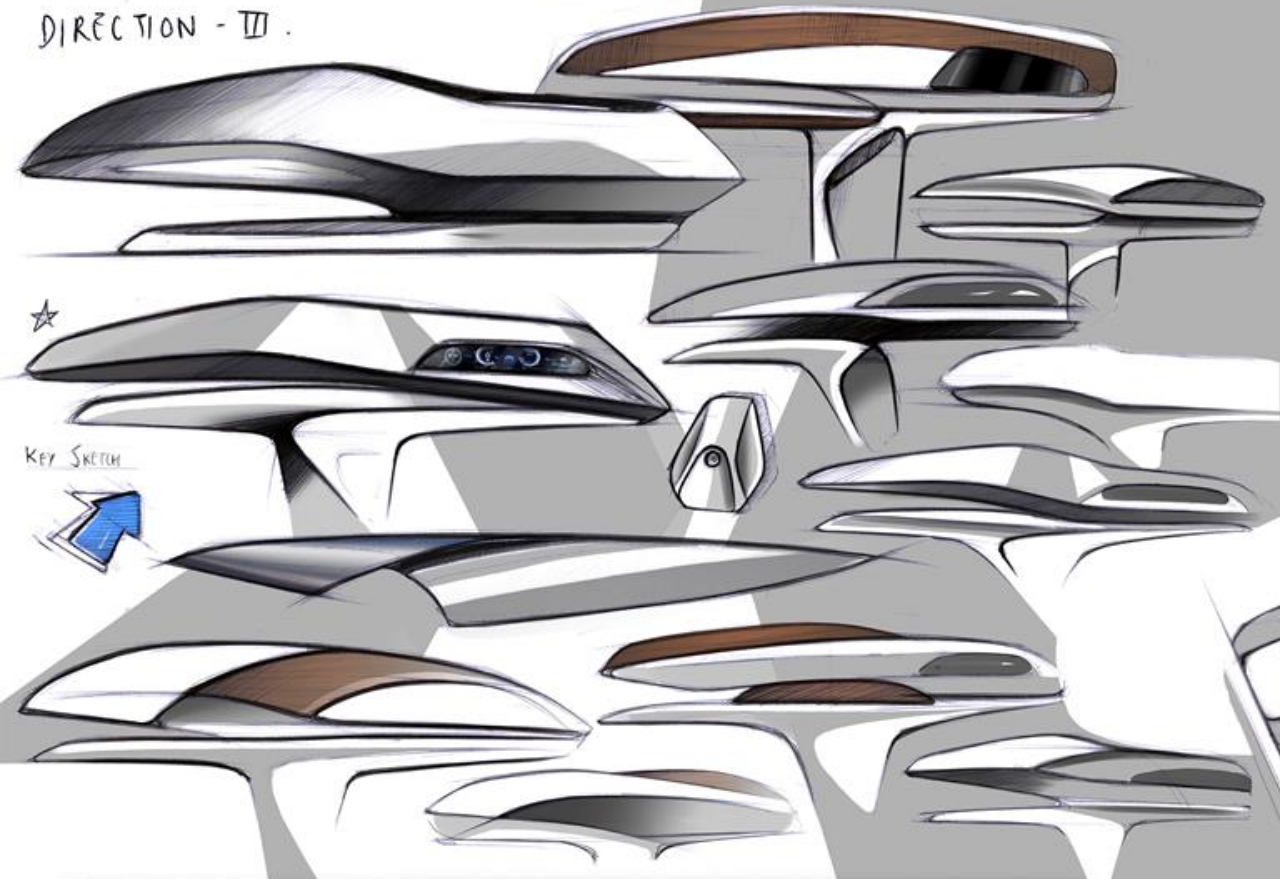

☆

Key SKETCH



PROBLEMS FACED

- STEERING WHEEL
- EMPTY SPACES

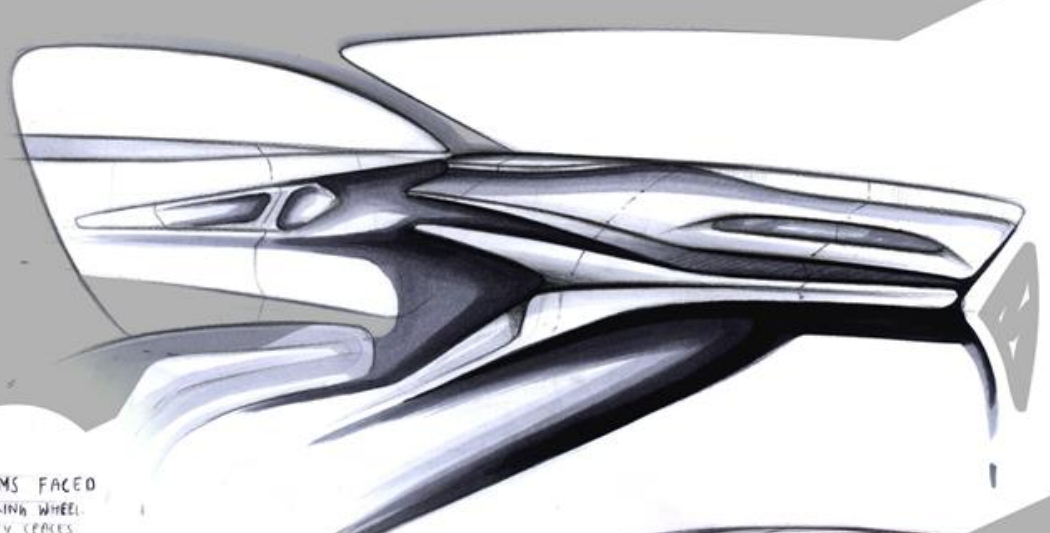

TWISTING SURFACE

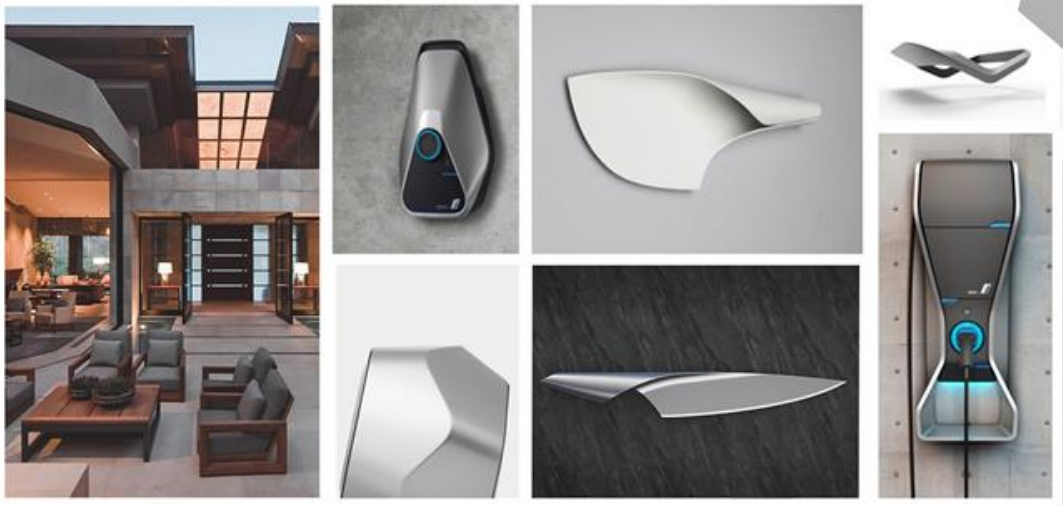

INSPIRATION BOARD

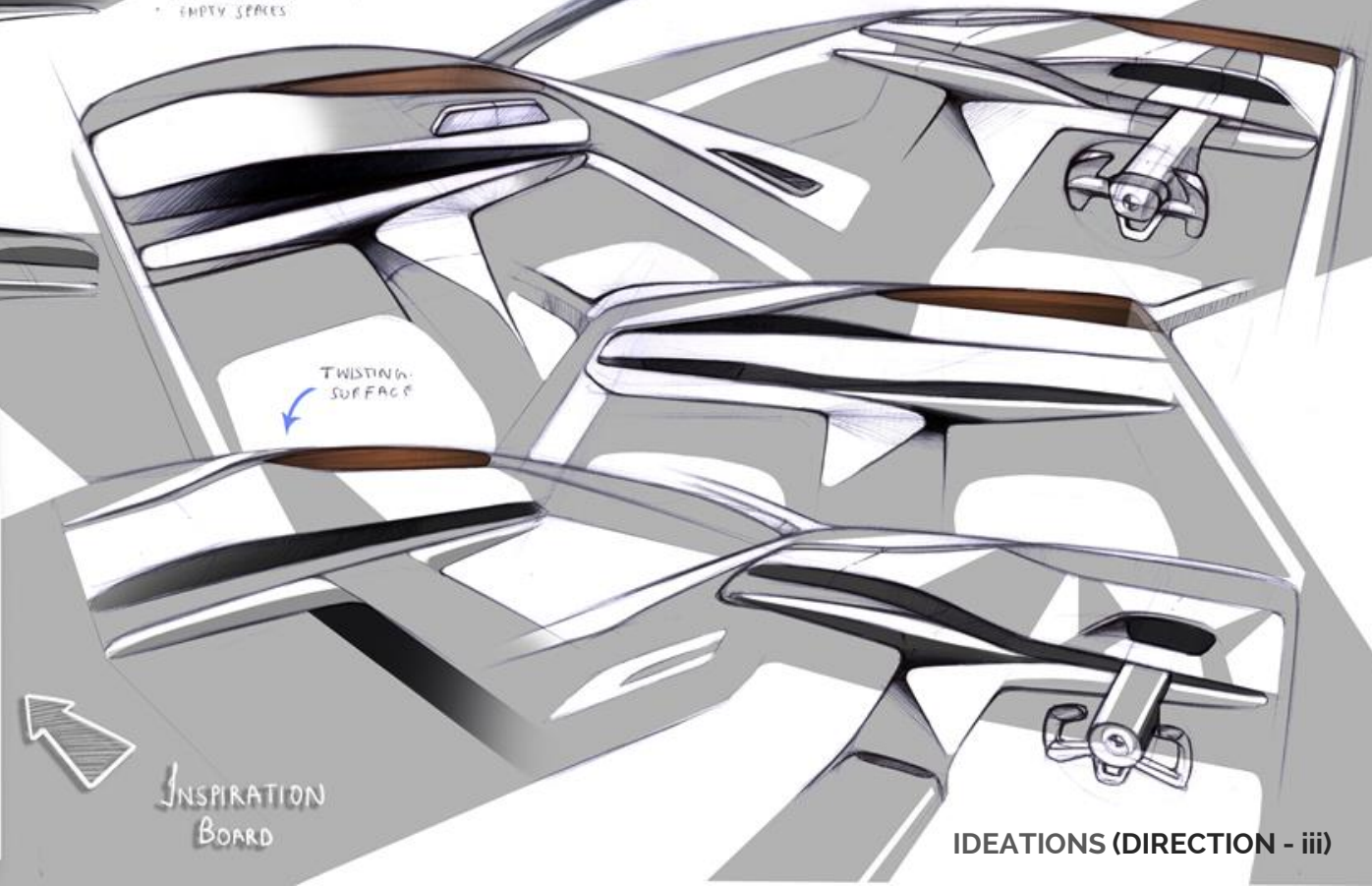

IDEATIONS (DIRECTION - iii)

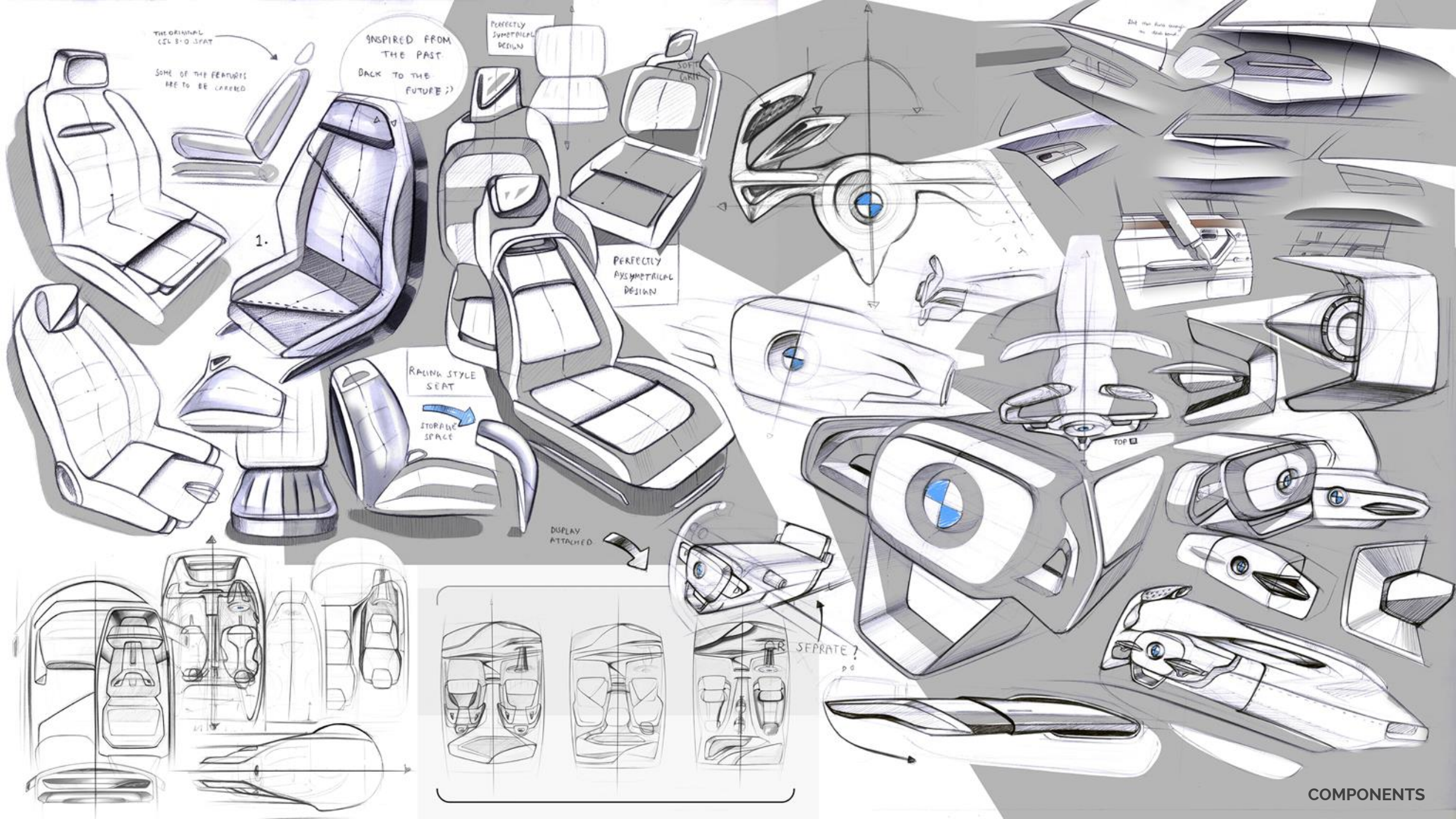

THE ORIGINAL
CEL 310 SEAT
SOME OF THE FEATURES
ARE TO BE CARRIED

INSPIRED FROM
THE PAST
BACK TO THE
FUTURE :)

PERFECTLY
SYMMETRICAL
DESIGN

PERFECTLY
ASYMMETRICAL
DESIGN

RACING STYLE
SEAT
STORAGE SPACE

DISPLAY
ATTACHED

SEPRATE!
p.p.

Did the first sketch
on this board?

TOP

COMPONENTS

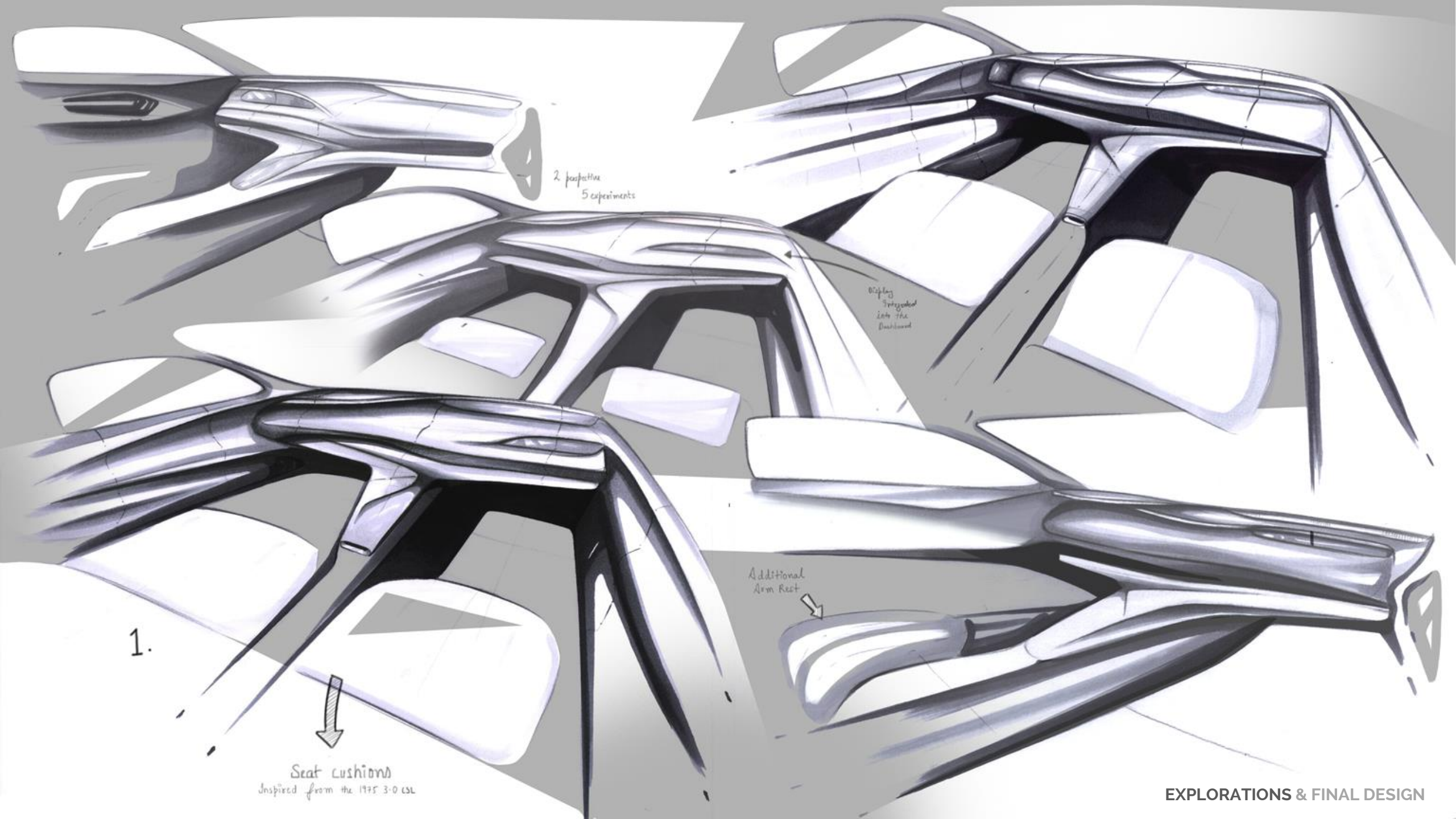

2 perspective
5 experiments

Display
Integrated
into the
Dashboard

1.



Seat cushions
Inspired from the 1975 3-0 CSL

Additional
Arm Rest



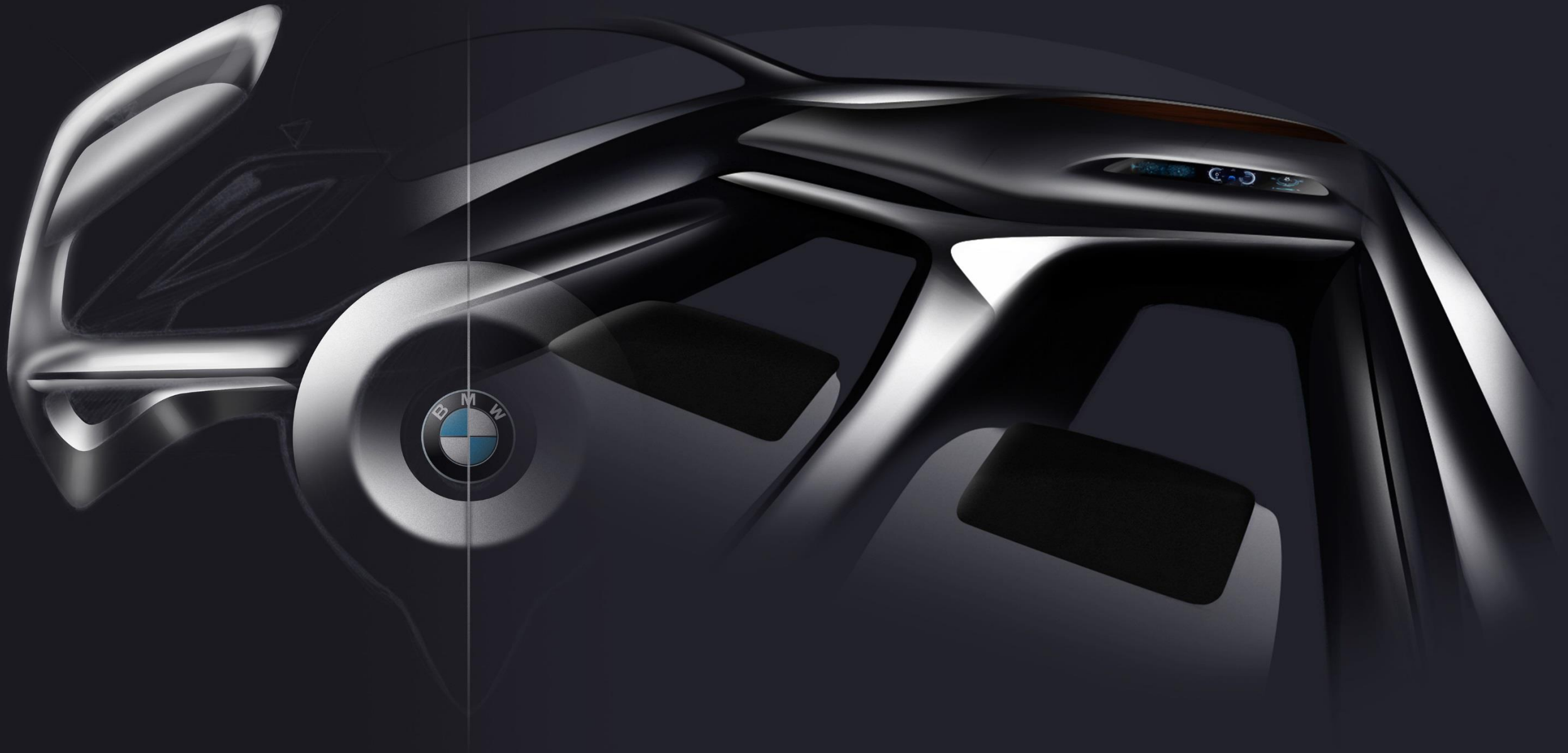



AUTO DESIGN DRAWING

the sketchbook

Acquainting Automobiles through sketching

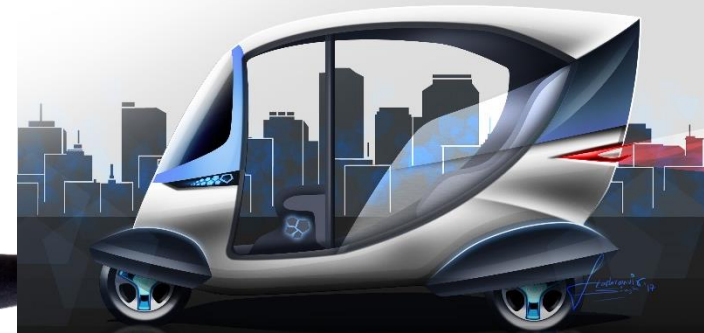
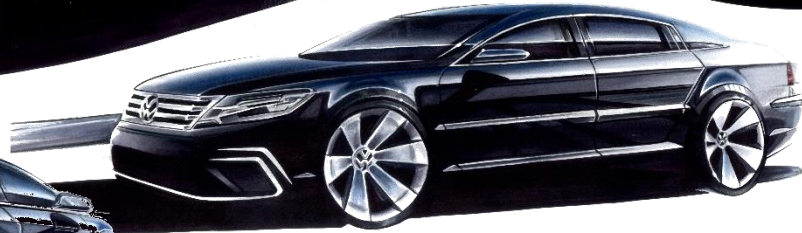
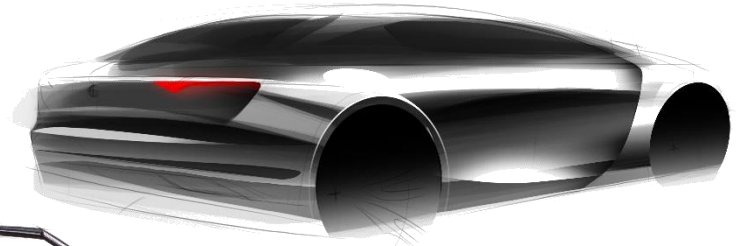
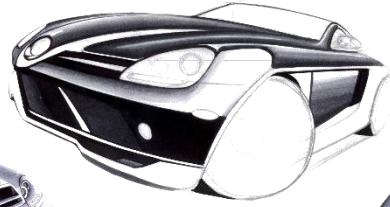

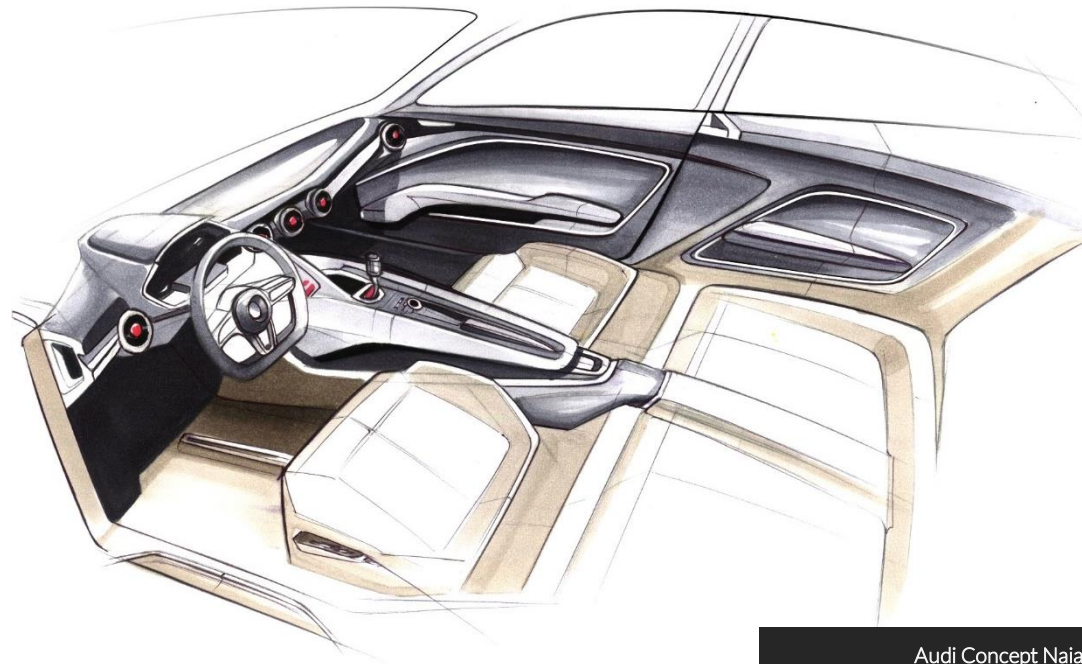
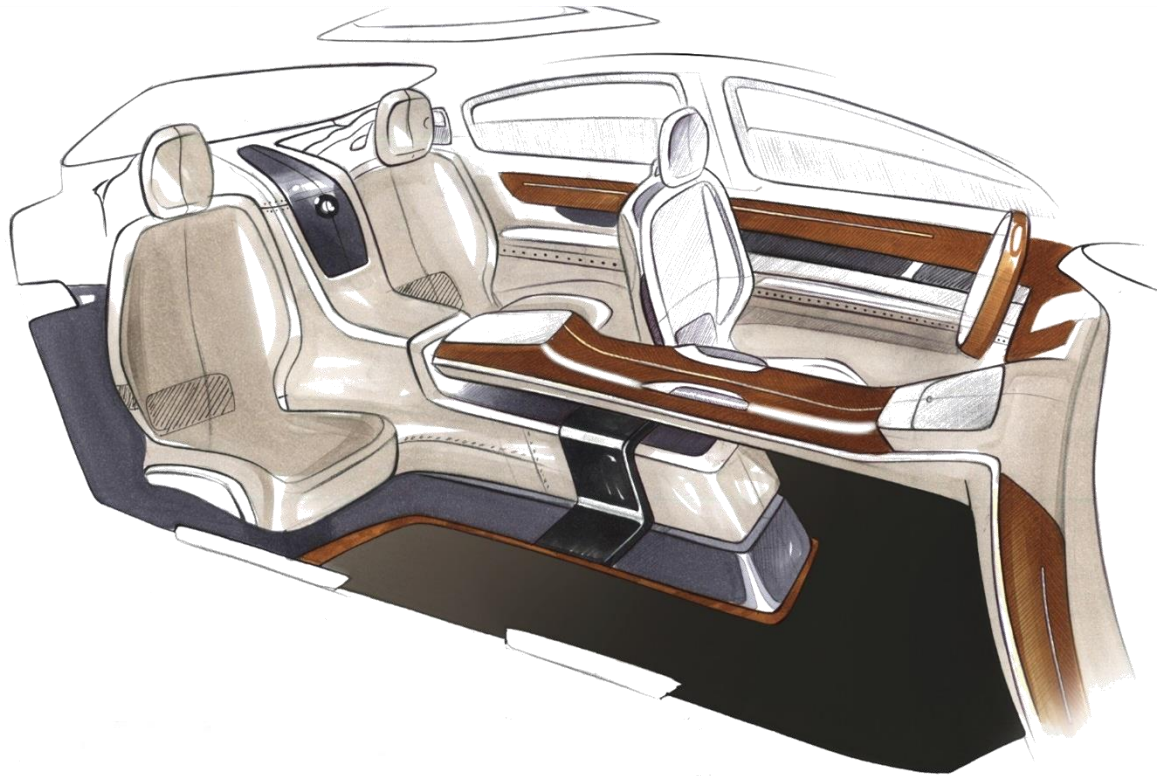

Audi Concept Naias
by Design Team

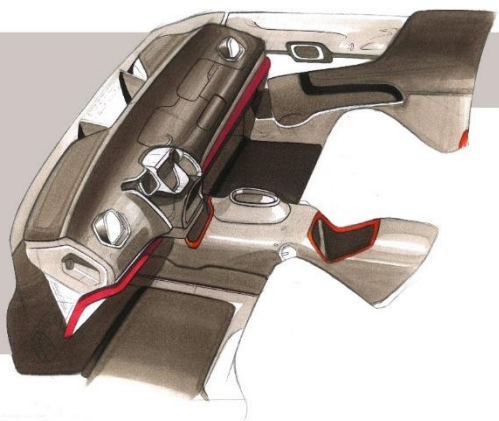

IMITATION RENDERS

Source : Pinterest

Any Four existing interior design sketches were to be imitated by us to acquaint with concept generation

To do the impression of other Designers & getting more into Concept Design. To further try out the methods & approaches used by Senior Designers.

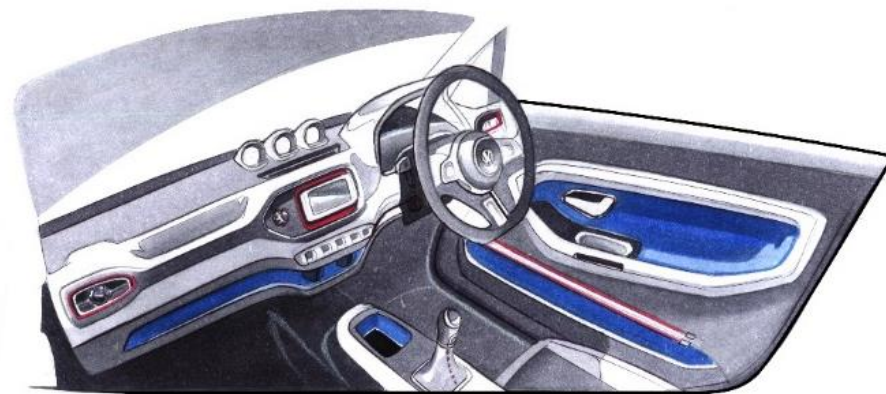

Volkswagen Taigun
by Srajevshi

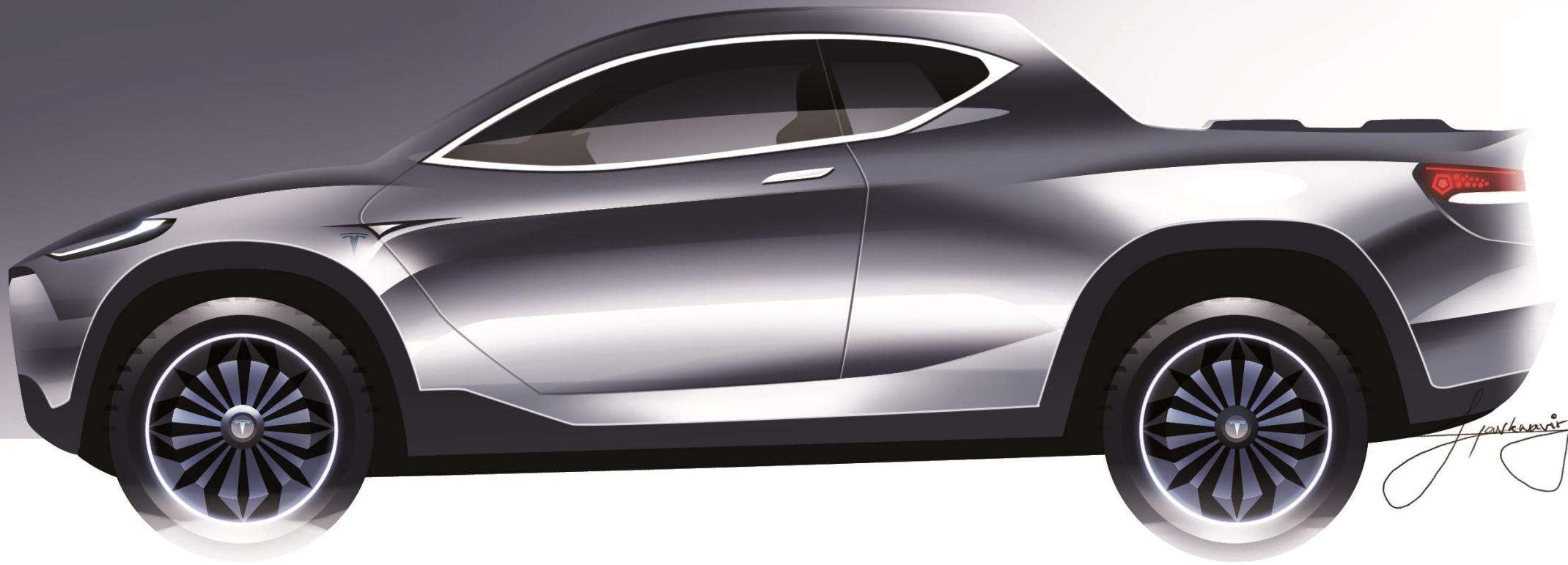

J. Parkkari Singh



THANKS FOR YOUR
TIME

WWW.BEHANCE.COM/HARKARANVIR

THANK YOU
CHEERS!

if you like what you see,
get in touch. Your advice
& thoughts are
welcomed.

Contact



+91 7986150015



www.linkedin.com/harkaranvir



harkaranvirs@gmail.com

