



Automotive **DESIGN**

Portfolio **2018**

Prashant **KHALKHO**

DYPDC School of Design

7559453363

pk.267099@gmail.com

PRASHANT KHALKHO

Transportation Designer

CONTACT

About Me

Destined to become a **Designer**, I **Envision** to bring about a **Change** through my **Works**. Looking forward to work and become an **Integral** part of your **Organisation**.

✉ pk.267099@gmail.com
☎ 7559453363

• Nationality - INDIAN

• Languages :-

- 🇮🇳 Hindi (Mother Tongue)
- 🇬🇧 English (Fluent)

Timeline

2016-18 ● M.Des (Transportation Design)

2010-14 ● B.Tech (Mechanical)

2010 ● HSC/SSC (St.Xavier's School)

01.02.1992 ● Born

Skills



B.Tech (Mechanical) 2010-14



JALANDHAR

BOKARO STEEL CITY

PUNE

School (St.Xavier's) 2010



M.Des (Automotive design) 2016-18



Hobbies



Design Quote

“ The Fundamental SOUL
of a man-made CREATION.”

Contents



RENAULT
Passion for life

HU[MAN]-ROBO RACE

GRAND TOURER
CONCEPT



RENAULT
Passion for life

**ELECTRIC
SCOOTER**



**PICK UP TRUCK
CONCEPT**



HYUNDAI
Motorsport

PROJECT RM



ROBO HU[MAN] RACING

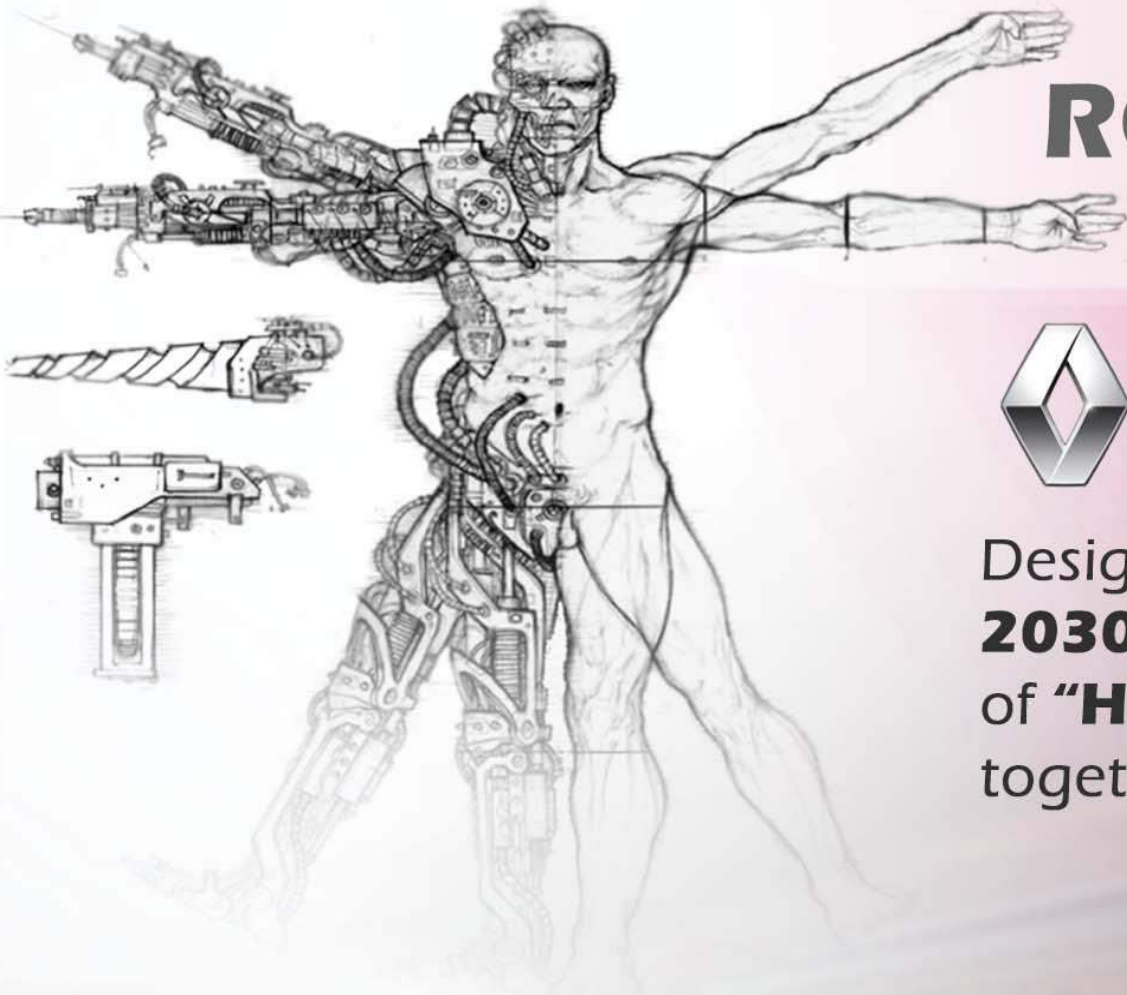

RENAULT
Passion for life

Design Brief

Design a Racing Solution for the year **2030** defining the **Synergy** and **Efficiency** of **“Human and Artificial Intelligence”** to work together.

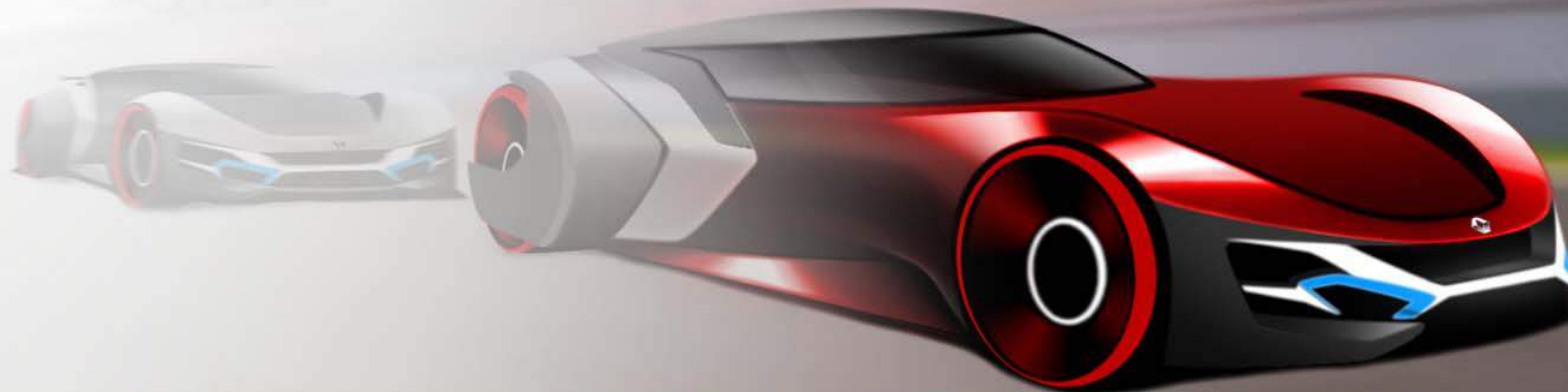



India by 2030

Top Populated Country

Rapid Urbanisation

350 GW
Renewable
Energy
Capacity



The Scenario

2030 marks the 30th anniversary of the commencement of a visionary project by the Indian Government of connecting the whole of India by a network of Highways (**THE GOLDEN QUADRILATERA**). The express highway connecting the Four Metro cities of India is of high significance boosting trade and commerce in India. To mark the successful running of the Highway a **Grand Rally Championship** is organised to showcase the significance of the express way.



Renault takes up the challenge and comes up with a **Grand Tourer Concept** inspired by the **Marvel Character Vision** to compete in the **Grand Rally championship**.

RACE SCENARIO 2030

Category - Time Speed and Distance Rally (6000 KM) + Circuit Racing

Leg (1 - 2) - Human Driver



Leg (3 - 6) - Automation Level Increases (Machine Learning)

Leg 7 - Complete Automation

Winning Criteria

- Minimum rally time penalty
- Fastest in Circuit Event



CHAMPIONSHIP

Leg 7 - Level 5 Automation

Leg 6 - Level 4 Automation

Leg 5 - Level 3 Automation

DELHI

662 km

Udaipur

761 km

MUMBAI

575 km

Hubballi

765 km

CHENNAI

MADRAS MOTOR RACE TRACK

BUDDHA INTERNATIONAL CIRCUIT

Leg 1 - No Automation

Leg 2 - No Automation

Leg 3 - Level 1 Automation

Leg 4 - Level 2 Automation

742 km

Allahabad

802 km

KOLKATA

882 km

Vizag

800 km

Track Event

DESIGN INSPIRATION

Creativity



OSTENTATIOUS



PRODIGIOUS

VISION

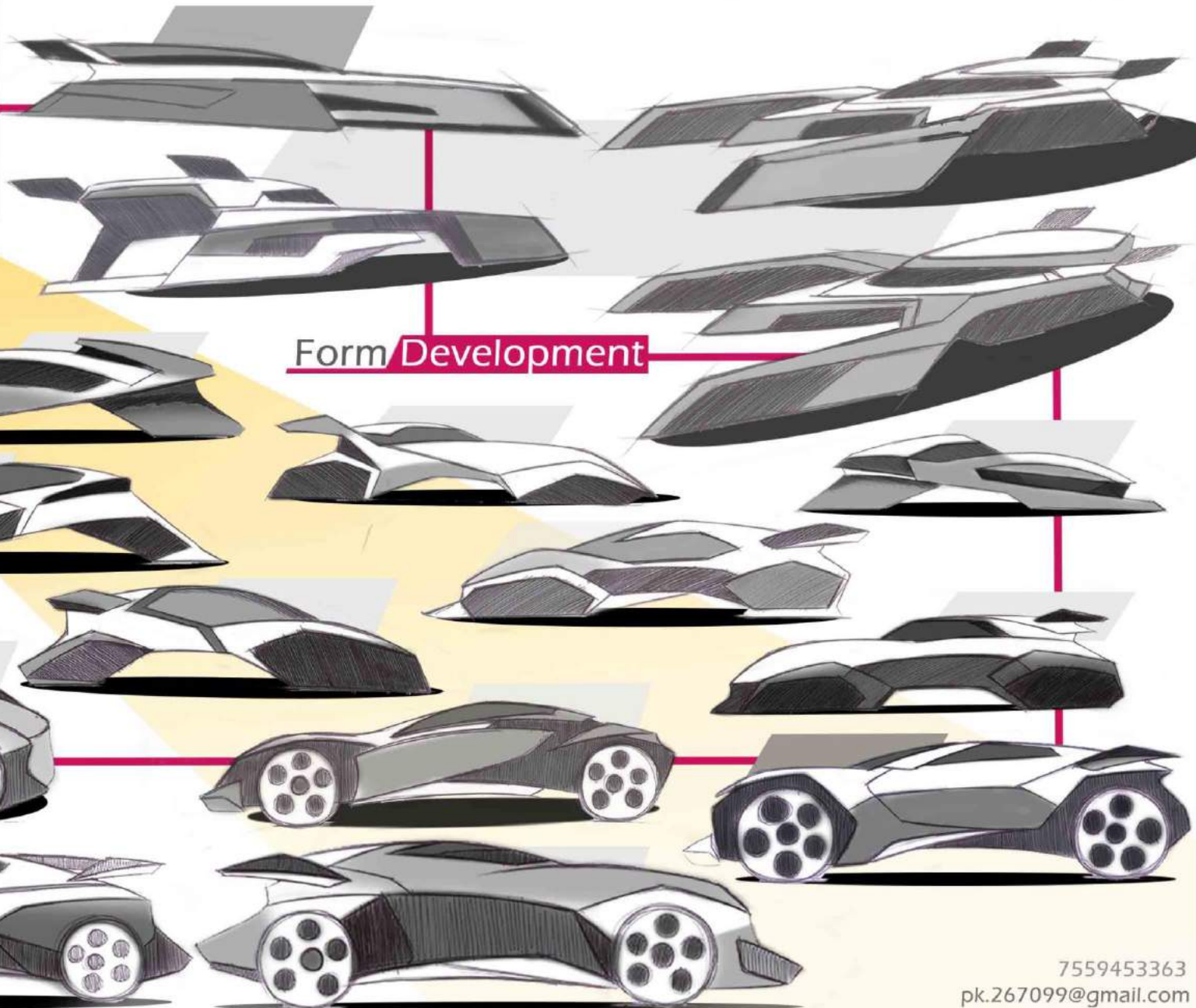

Form Development

Sketch Board

Design Development

Concept
Ideations

Final Sketches

7559453363

pk.267099@gmail.com



Technical Aspects



RENAULT
Passion for life



Tech Pack

TESLA TURBINE

The Tesla turbine is a bladeless centripetal flow turbine patented by Nikola Tesla in 1913. It is referred to as a bladeless turbine. The Tesla turbine is also known as the boundary layer turbine, cohesion-type turbine, and Prandtl layer turbine (after Ludwig Prandtl) because it uses the boundary layer effect and not a fluid impinging upon the blades as in a conventional turbine. Bioengineering researchers have referred to it as a multiple disk centrifugal pump.

- Average Car - 3000-5000 RPM
- Formula 1 - 18000 - 20000 RPM
- Tesla Turbine - 52000 RPM
- Unlimited Source of Power
- Green Energy
- Light Weight

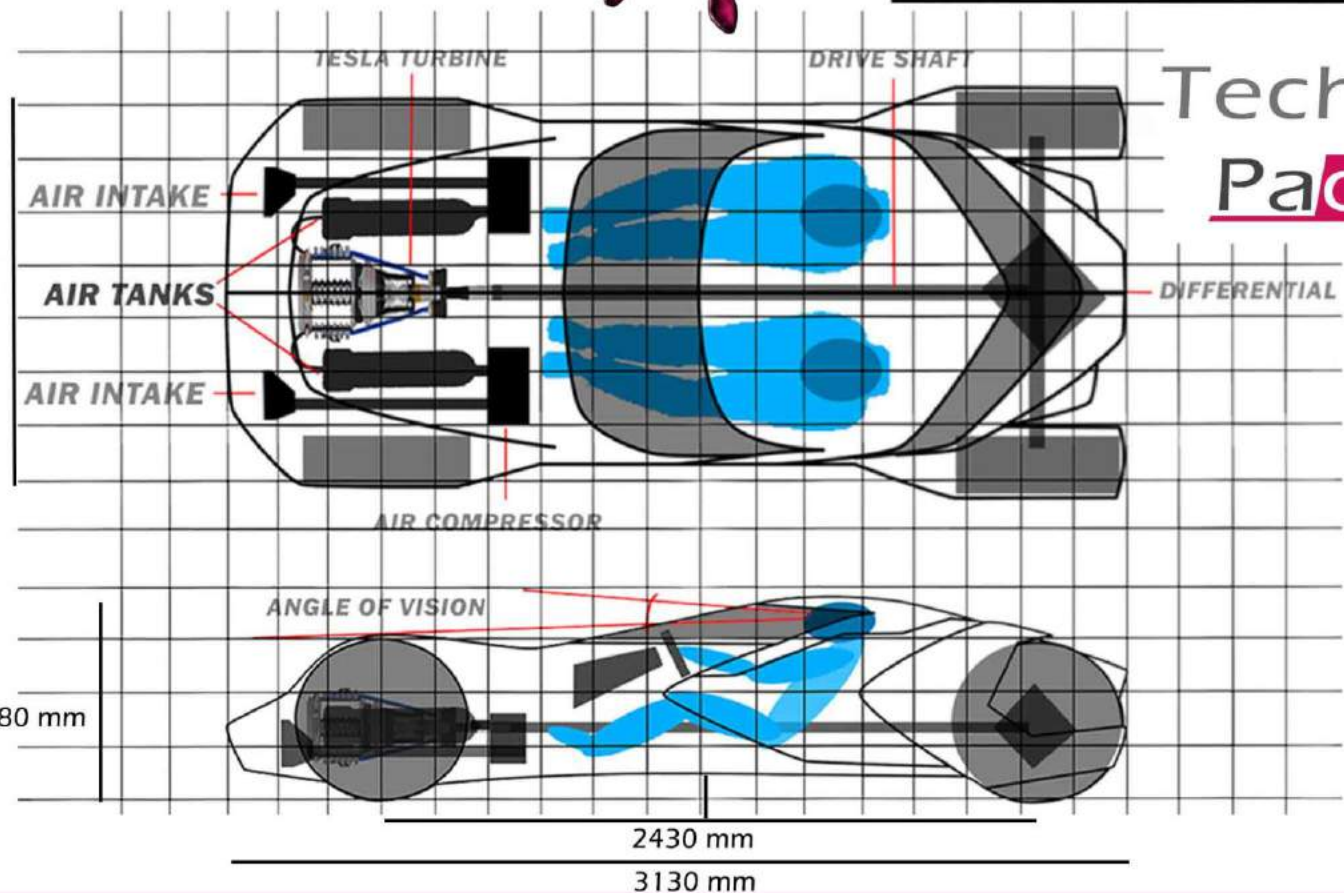

Final Design Proposal

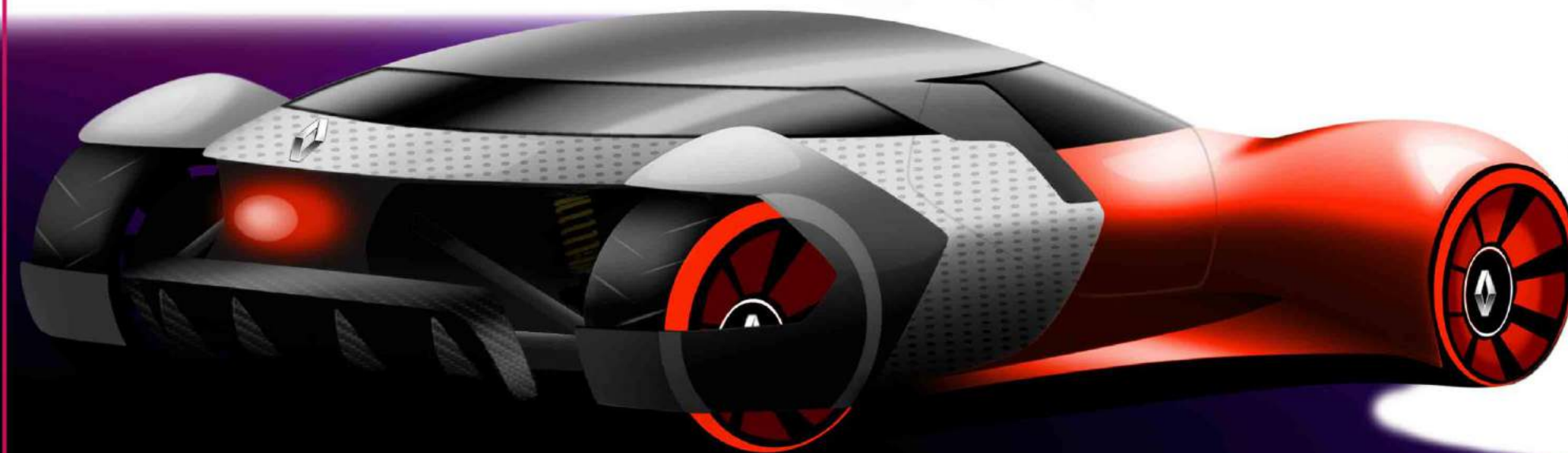

RENAULT
Passion for life



RENAULT
Passion for life



7559453363
pk.267099@gmail.com

The background of the slide is a green-tinted image of a Renault electric scooter concept. The scooter is shown from a side profile, facing left. It has a modern, aerodynamic design with a large front fairing and a smaller rear fairing. The wheels are multi-spoke alloy wheels. The overall aesthetic is clean and futuristic.

Design Brief

Renault realizes the potential of **Two Wheeler** segment in India, as India has become the it's **Largest market**. Thus Renault comes up with it's **Electric Scooter Concept** to hit the Indian Roads.

Research and Analysis



RENAULT
Passion for life

For more than 120 years, Renault has developed automotive solutions that make mobility easy and accessible for customers around the world.

Founders



Louis Renault
Marcel Renault
Fernand Renault



Timeline at a Glance

Global Warming and Climate Change

Root Causes

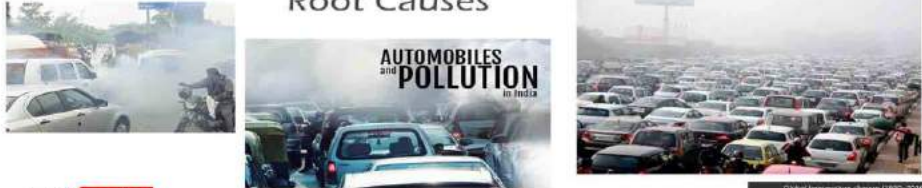

Effects



One of the Many Solutions

- Cheap to run
- Low Maintenance
- No Emission
- Environment Friendly



Electric Scooter Market

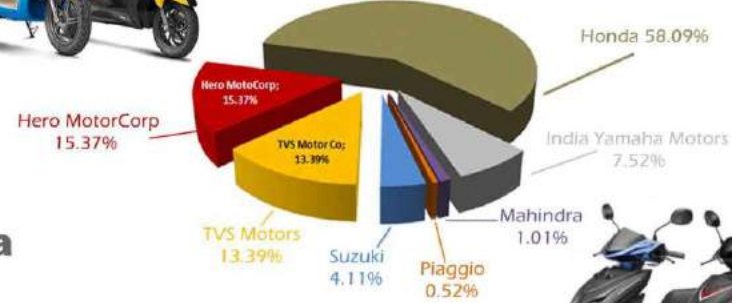

Creativity and Ideation

Design Inspiration



Sketch Board

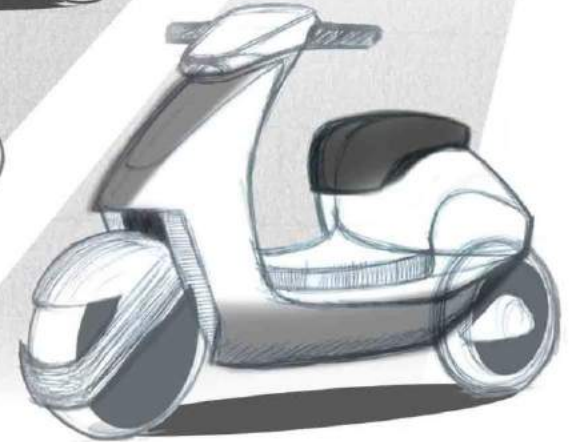
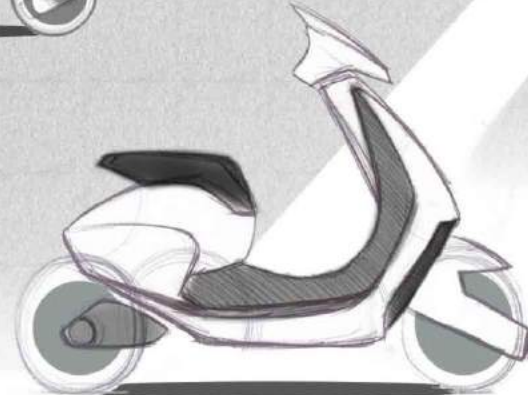
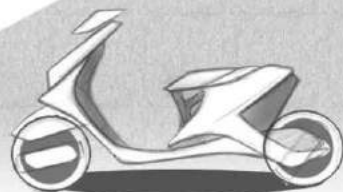
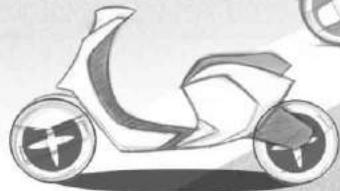
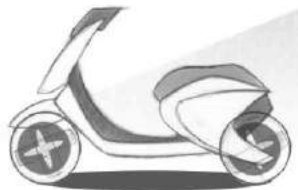
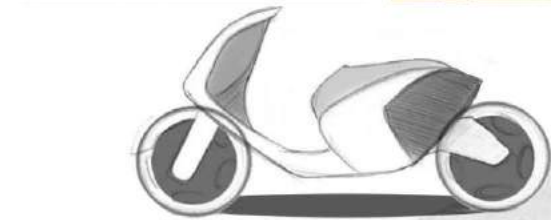

Final Sketches

Technical Parameters

Seating Position

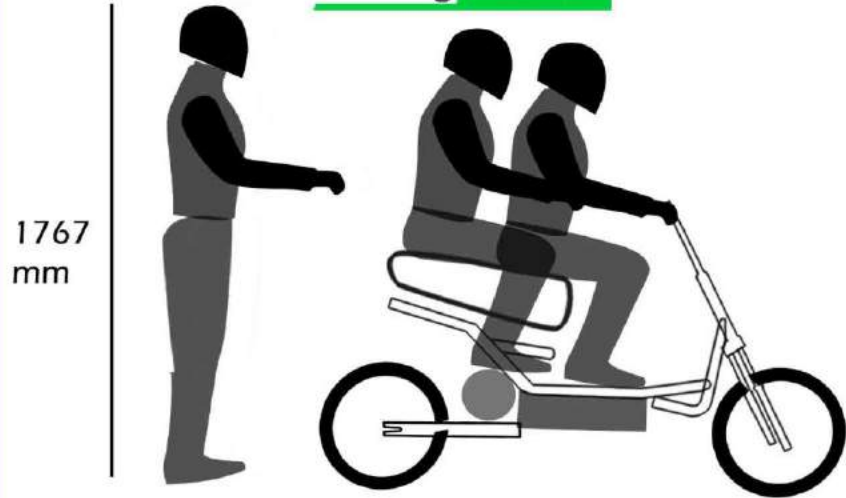

Upright Seating Position for Comfortable Ride

Easy Access of Charging Point

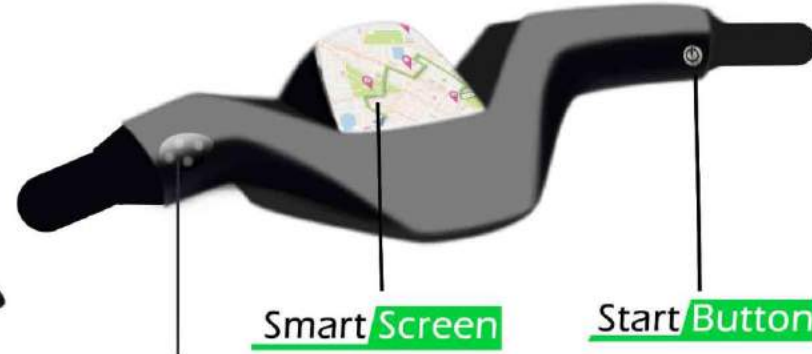
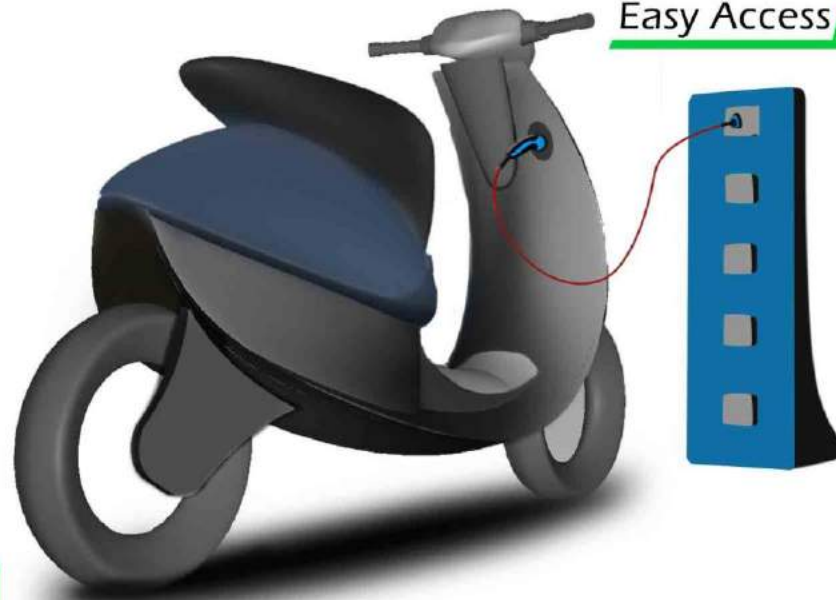

Smart Screen

Start Button

Manual Controls

Tech Pack

Easy Battery Accessing

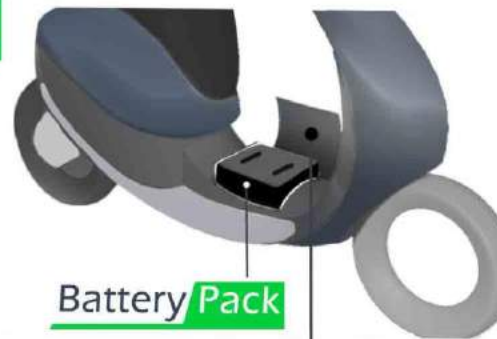

Battery Pack

Battery Compartment Lid

Cargo Storage Space

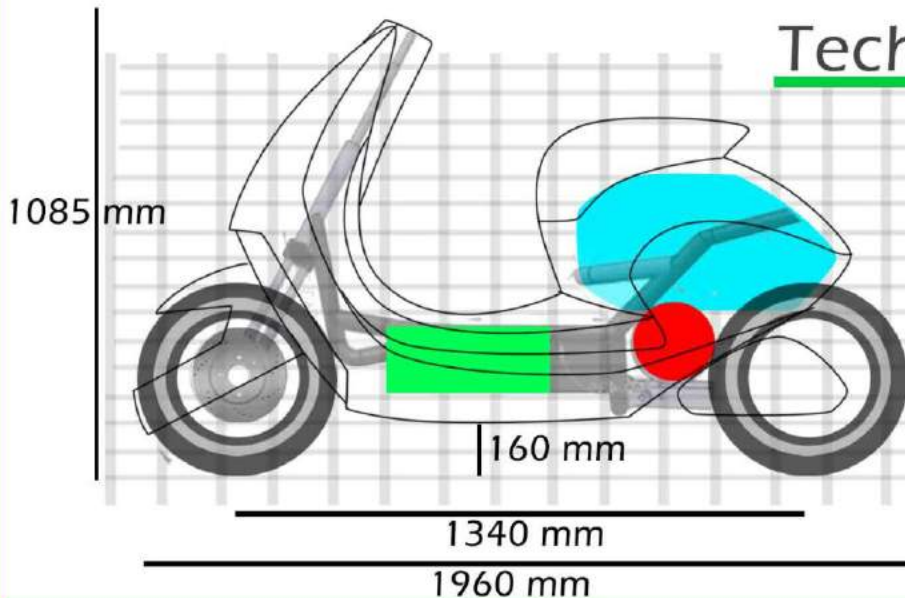
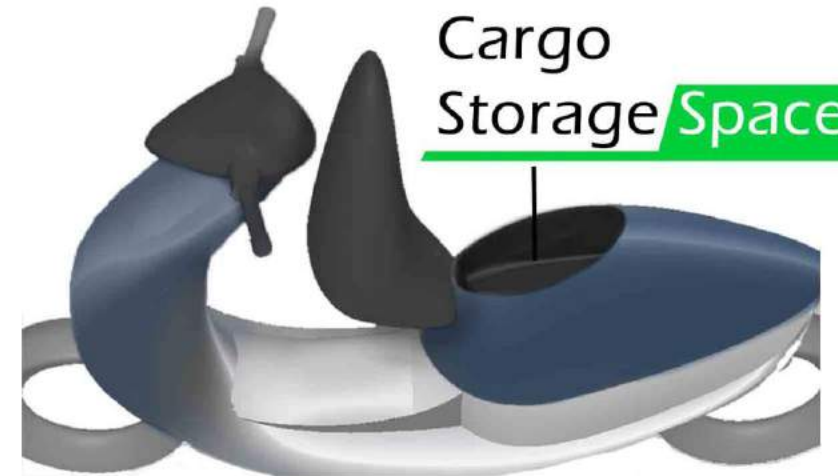

785 mm

- Boot Space
- Battery pack
- Motor

Final Design Proposal

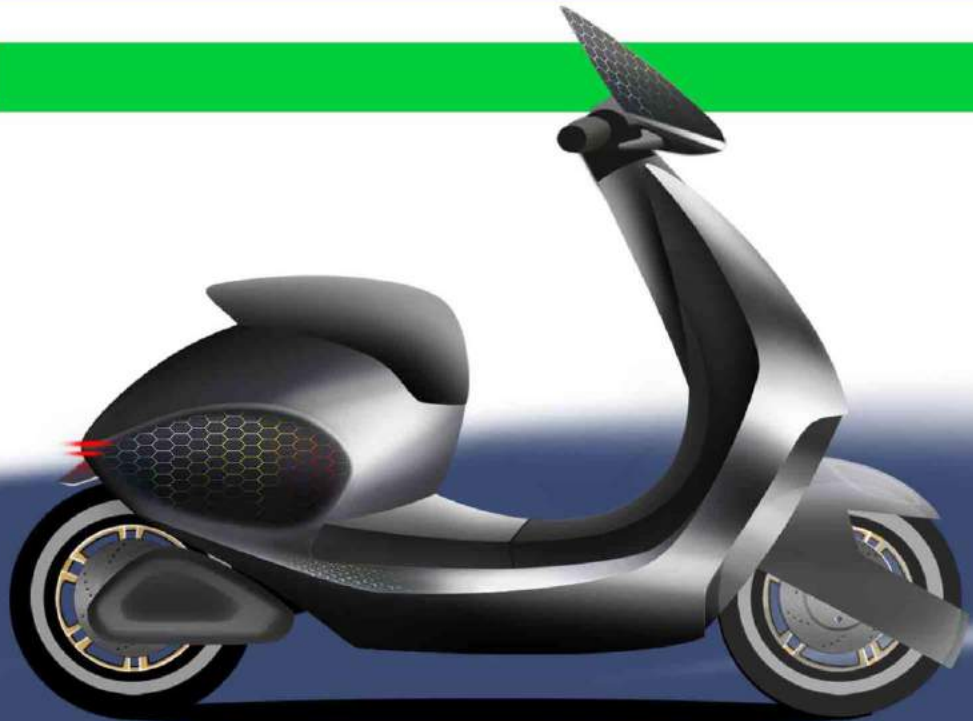

RENAULT
Passion for life

7559453363
pk.267099@gmail.com



Design Brief

On Acknowledging the potential rise of **Pick - Up Truck** Market in **India** in the years to come, **Morris Garages** plans to steps into the **Indian Market** by launching a promising **Lifestyle Urban Pick-Up Truck**. Thus Proving its Mettle as a reliable automobile company.

Research and Analysis



MORRIS GARAGES

The Brand Story

The origin of the brand's name - **Morris Garages** - can be traced back to 1921 when motor manufacturer **William Morris** hired **Cecil Kimber**. The story of MG (Morris Garages) began in **1924** in the **UK**.

William Richard Morris



Cecil Kimber

Founders



Past

Yester years



MG3

MG5



MG GT

MG GS



Morris Garges in Recent Times



2016

MG ZS



2017

MG E Motion



2018

MG X Motion

Indian Pick-Up Truck Market

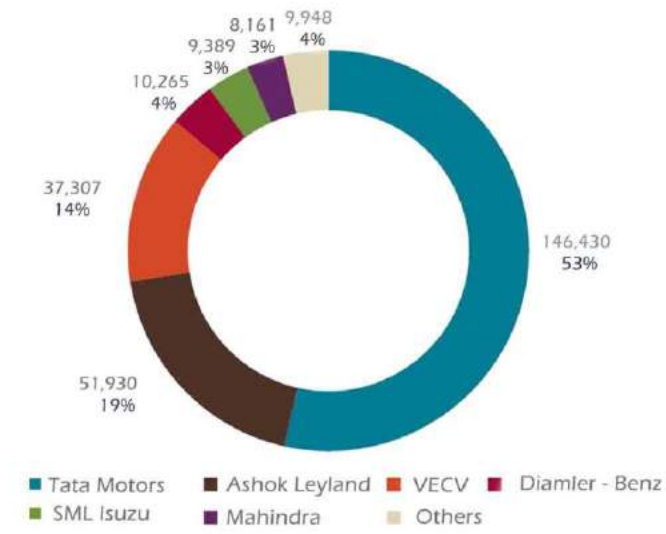
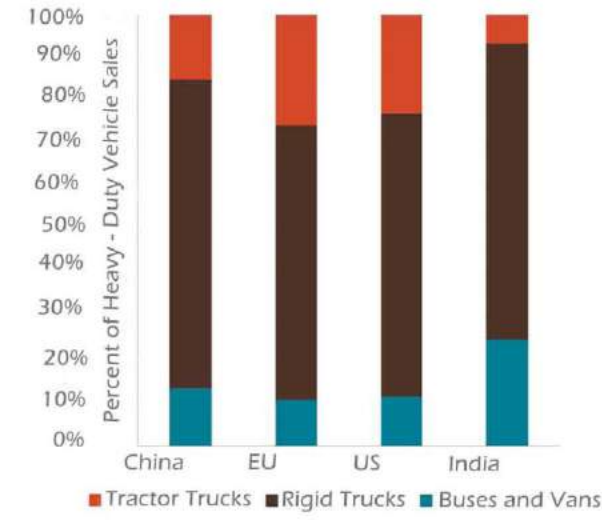

Sales Breakdown for Commercial Vehicles

Market Share Pick Up truck in India



Camper



Scorpio Pick-up



D-Max



Xenon



Imperio

Competitors for Indian Market

Creativity

Gaurav Taneja

Age -32

Profession - Commercial Pilot

User Persona



Mood Board



Tough



Adventurous



Aggressive

Design Inspiration

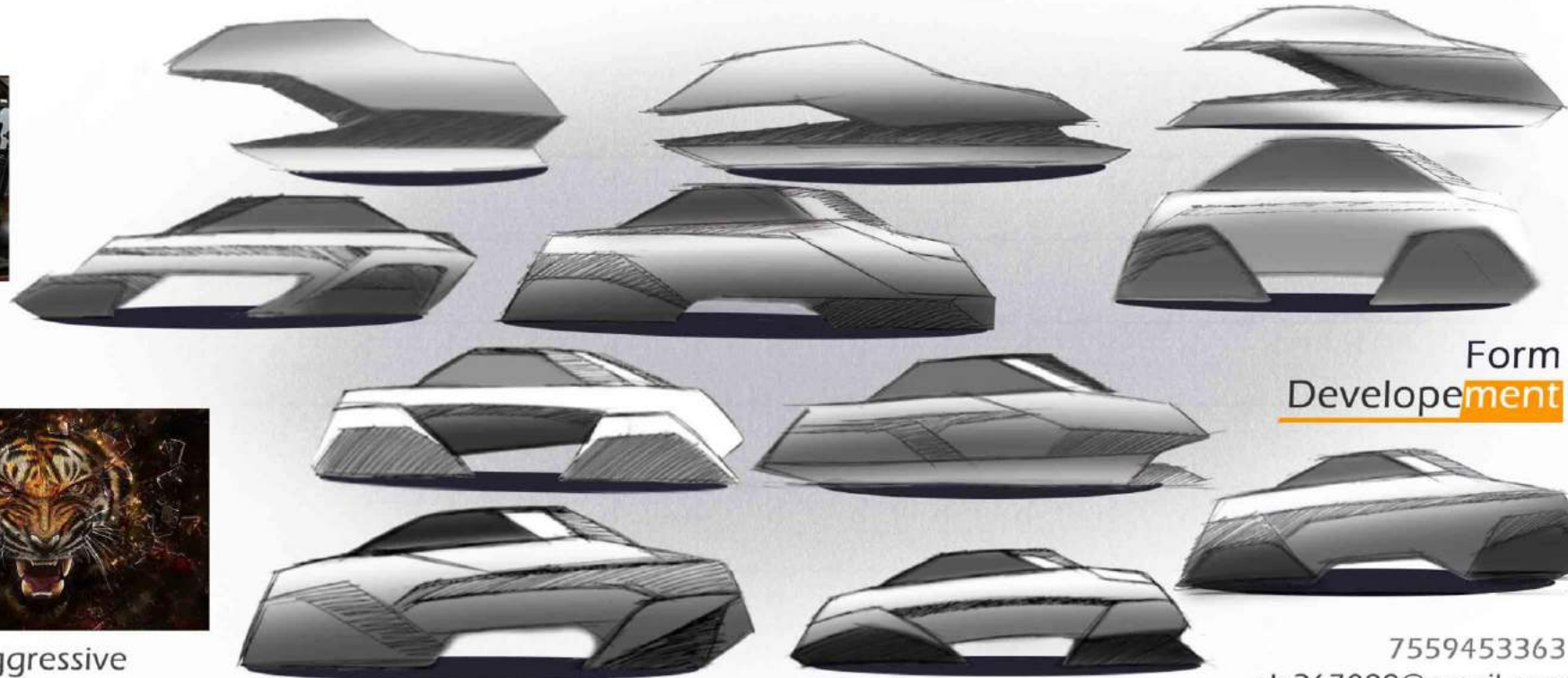

Form Development

7559453363
pk.267099@gmail.com

Design Development



Sketch
Board

Final Sketch

7559453363
p.267099@gmail.com



Technical Aspects



Monocoque Chassis Frame

Monocoque frame adds to the rigidity of the vehicle and is light weight in Nature. It is better than the Standard Body - on - Frame Chassis for the Urban Lifestyle customer category over the conventional ladder frame used for commercial trucks. The Chassis is Intentional Exposed on the Exterior giving it a completely fresh look.

Tech Pack

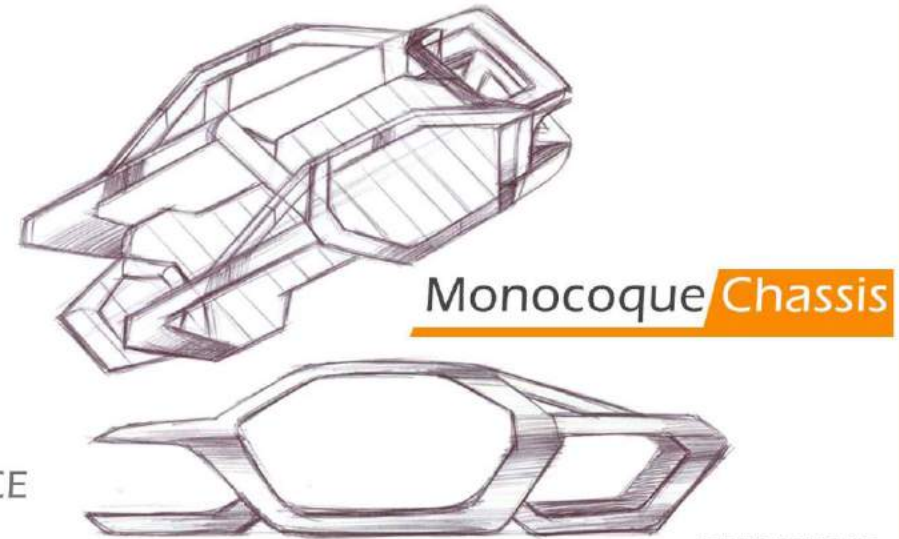
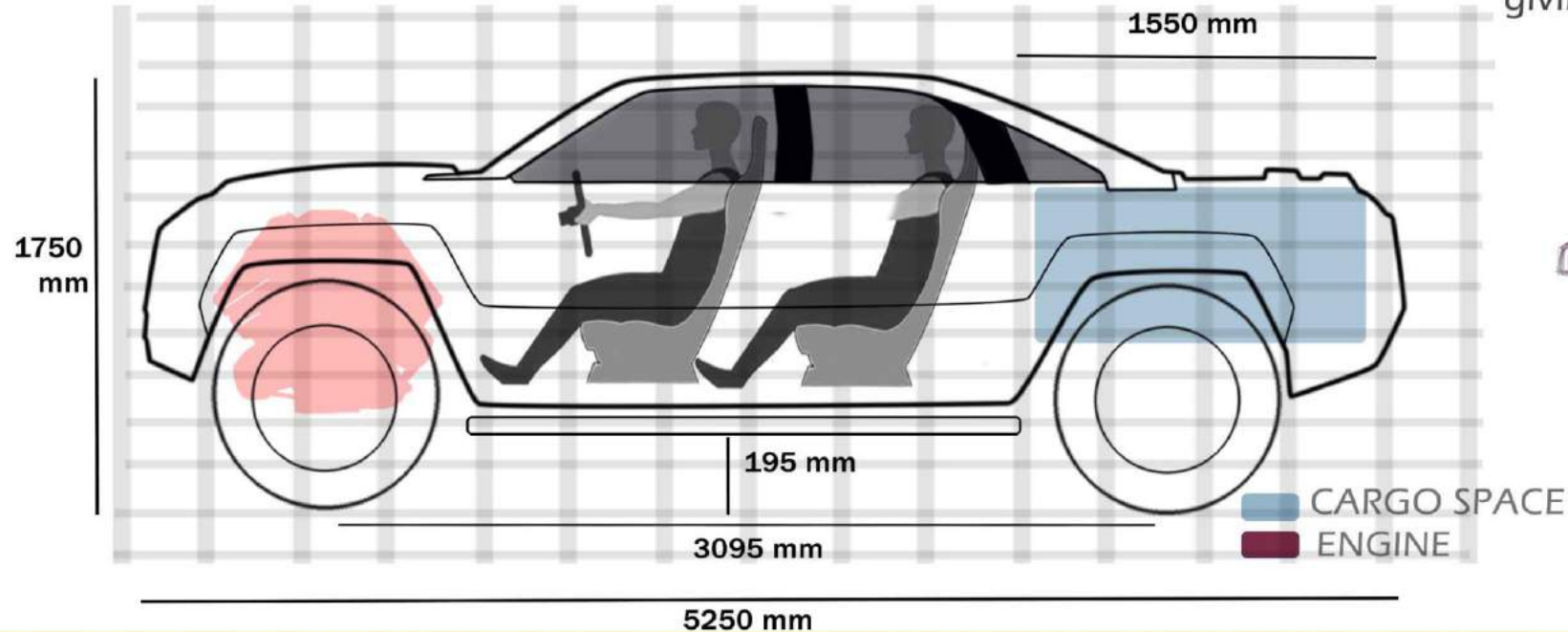

Final Design Proposal

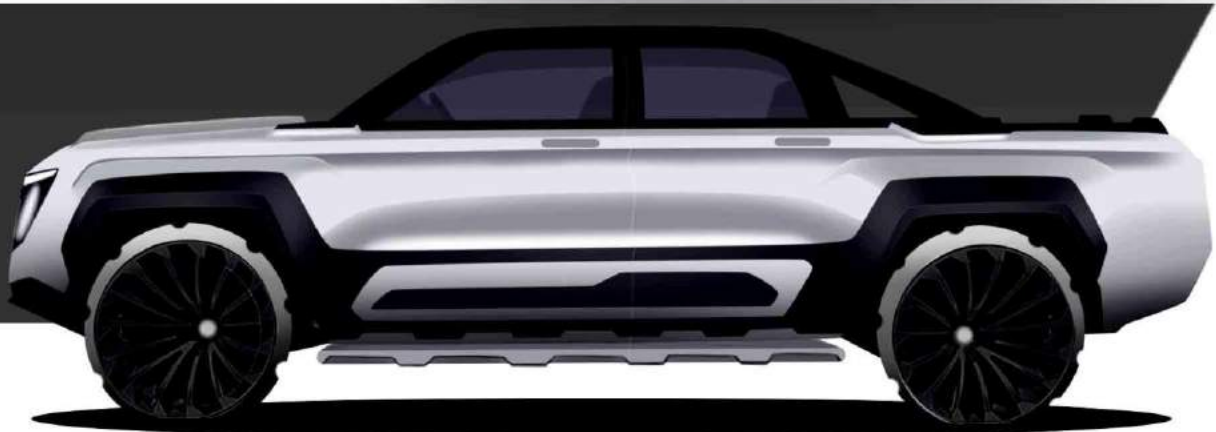



7559453363
pk.267099@gmail.com



HYUNDAI
Motorsport



High Performance

Design Brief

Project RM (RACING MIDSHIP) launched before **Hyundai's High Performance N sub-brand** with a goal to go beyond limits of the **High-Performance Technologies** that will be applied to the **future N model**. Thus the brief is to design a **High Performance Electric Sports Car** for the **RM Series** named **RM20**.

Research and Analysis



HYUNDAI New Thinking, New Possibilities.

About The Company

- FOUNDER - CHUNG JU YUNG
- FOUNDED - DECEMBER 29, 1967
- HEADQUARTERS - SEOUL, SOUTH KOREA
- CEO - CHUNG MONG-KOO
- PARENT ORGANIZATION - HYUNDAI MOTOR GROUP
- DIVISIONS -



HYUNDAI N 2025 VISION GRAN TOURISMO



PROJECT RM



HYUNDAI MOTORSPORT (WRC)

Design Philosophy

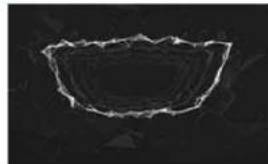
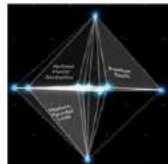

(Fluidic Sculpture 2.0)

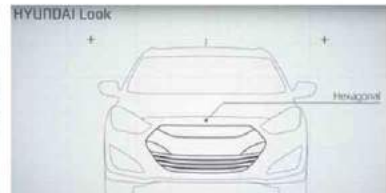

Project Racing Midship

- Tech bridge between Motorsports and High Performance N Vehicles.

- A "rolling lab" for testing the high-performance technologies.

- Meeting the challenge of systematic development of a high-performance technology



i30N

THE RN30 CONCEPT

- FIRST BPM MACHINE



VELOSTER N

- The MISCHIVIOUS DISTRUPTOR



RM14

RM15

RM16

- Design of RM16 –the embodiment of "low & wide"

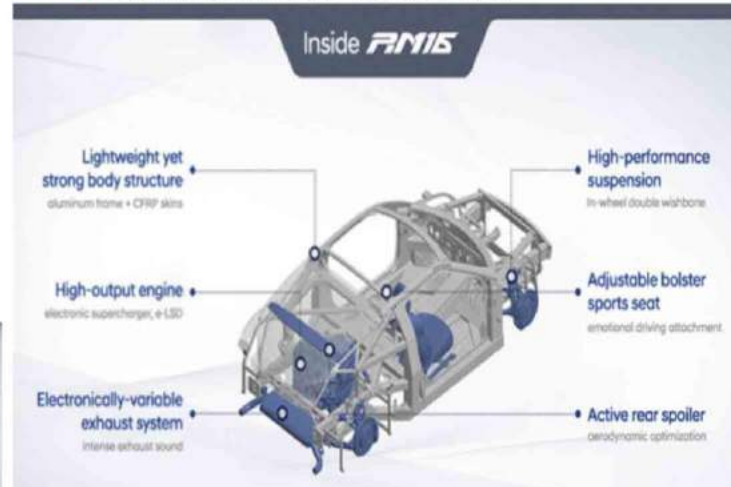

- The RM 16 new technology, a relentless test to go beyond the limits.

Creativity

User Persona



Karun Chandok
Age - 34
Profession - Indian Racing Driver



Design Inspiration



Mood Board



Blistering



Gallant



Venturous

Initial Sketches

Design Development

Sketch Board



Final Sketches

7559453363
pk.267099@gmail.com

Technical Aspects



HYUNDAI

Motorsport High Performance



RM 20 Concept

Project Racing Midship

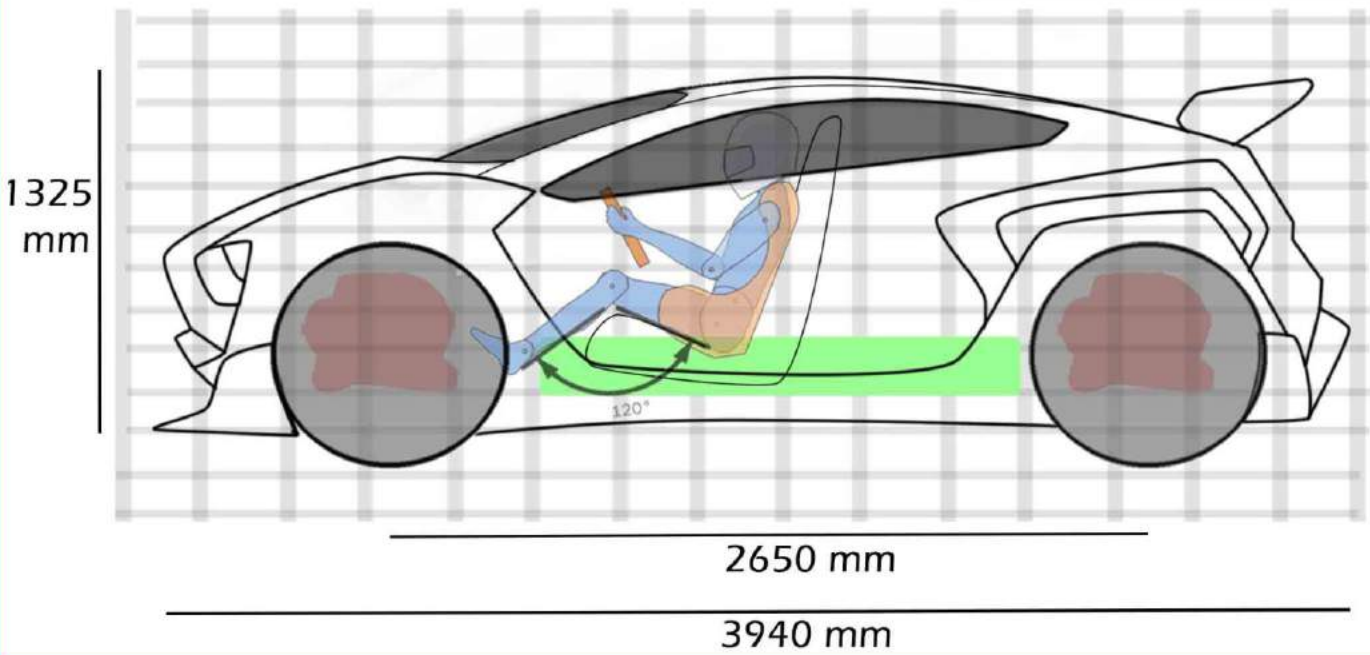
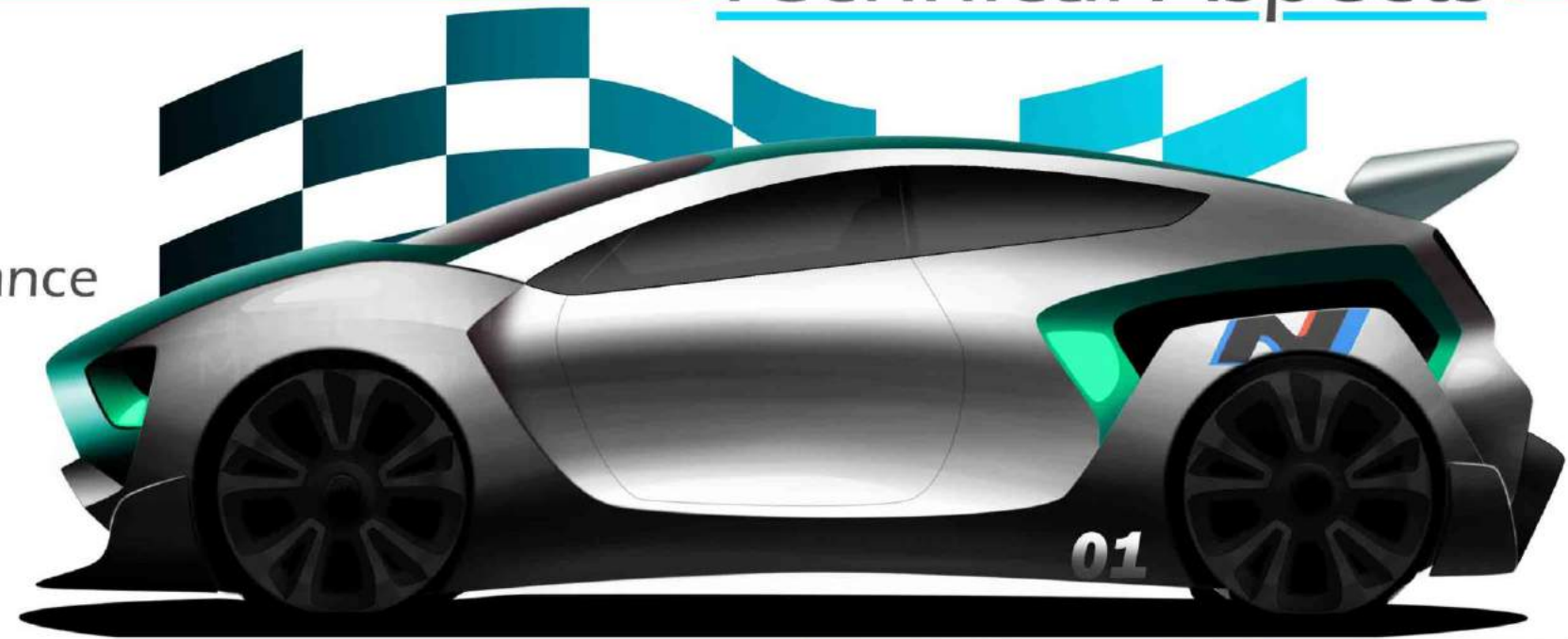

Tech Pack

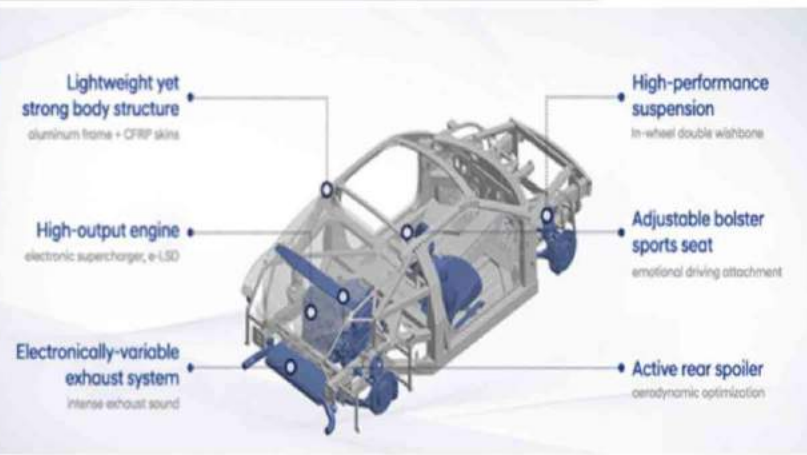

- Battery Pack
- High Performance Motors

Chassis Design

7559453363
pk.267099@mail.com

Final Design Proposal

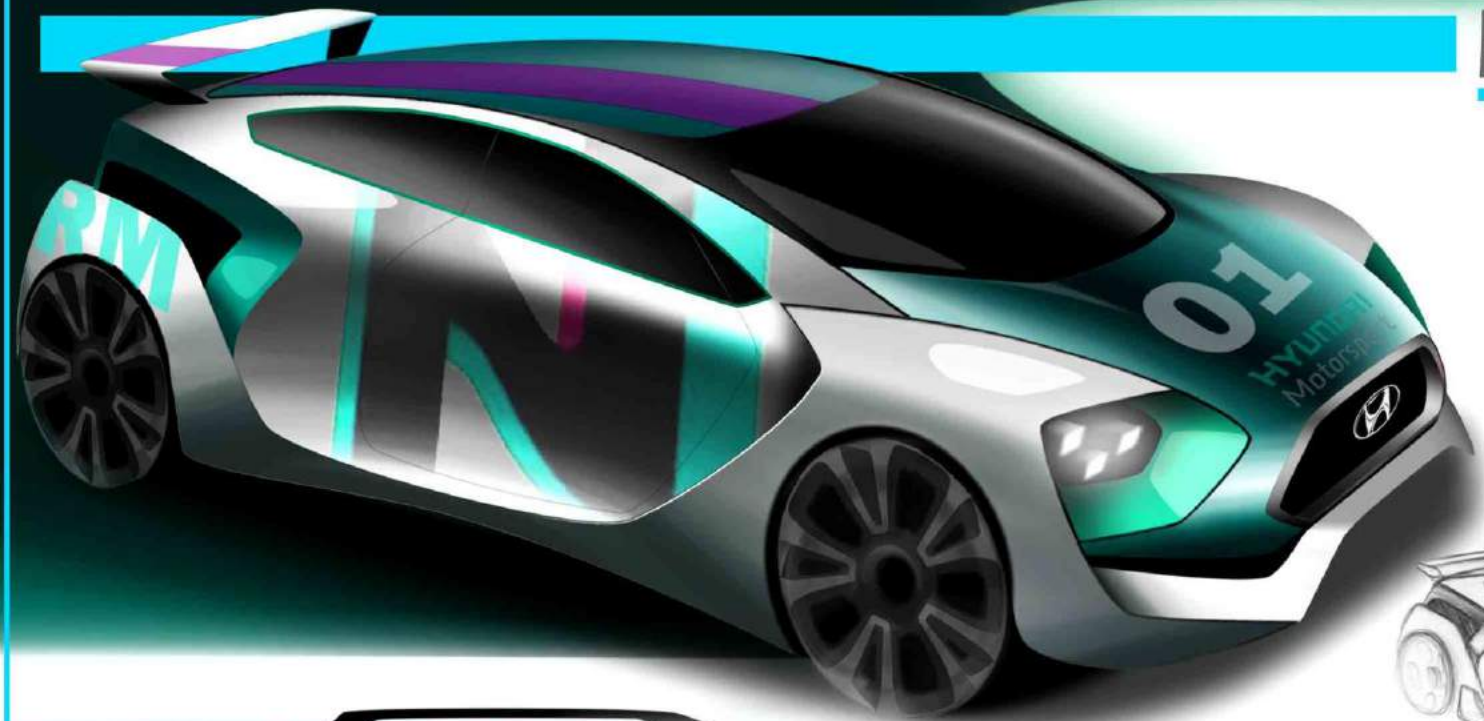

HYUNDAI
Motorsport



High Performance

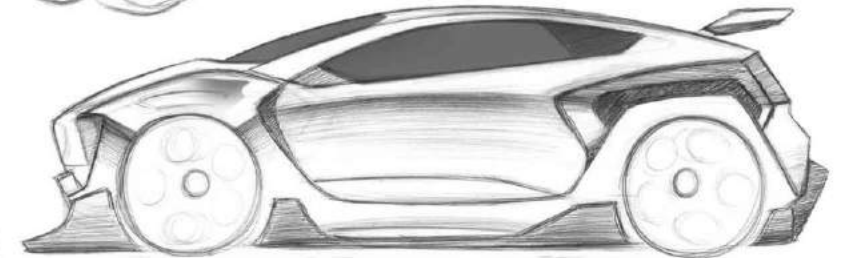
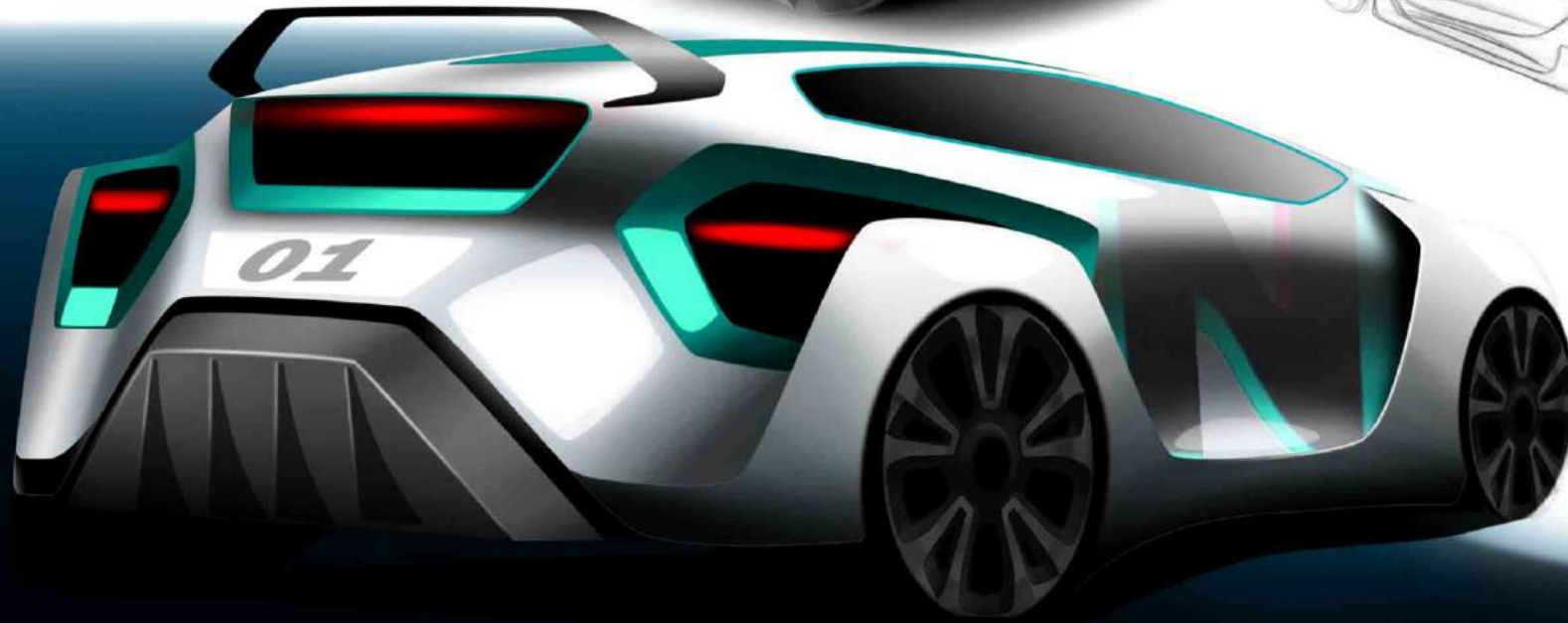
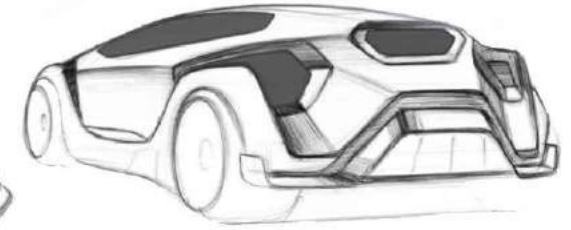
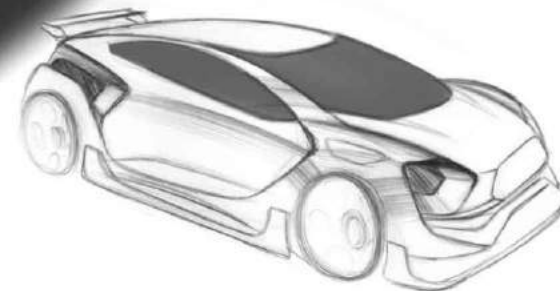



HYUNDAI
Motorsport

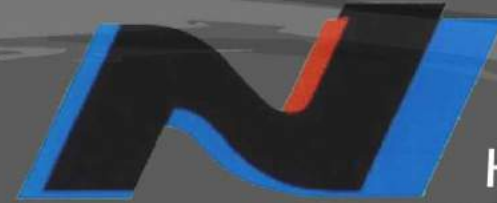

High performance

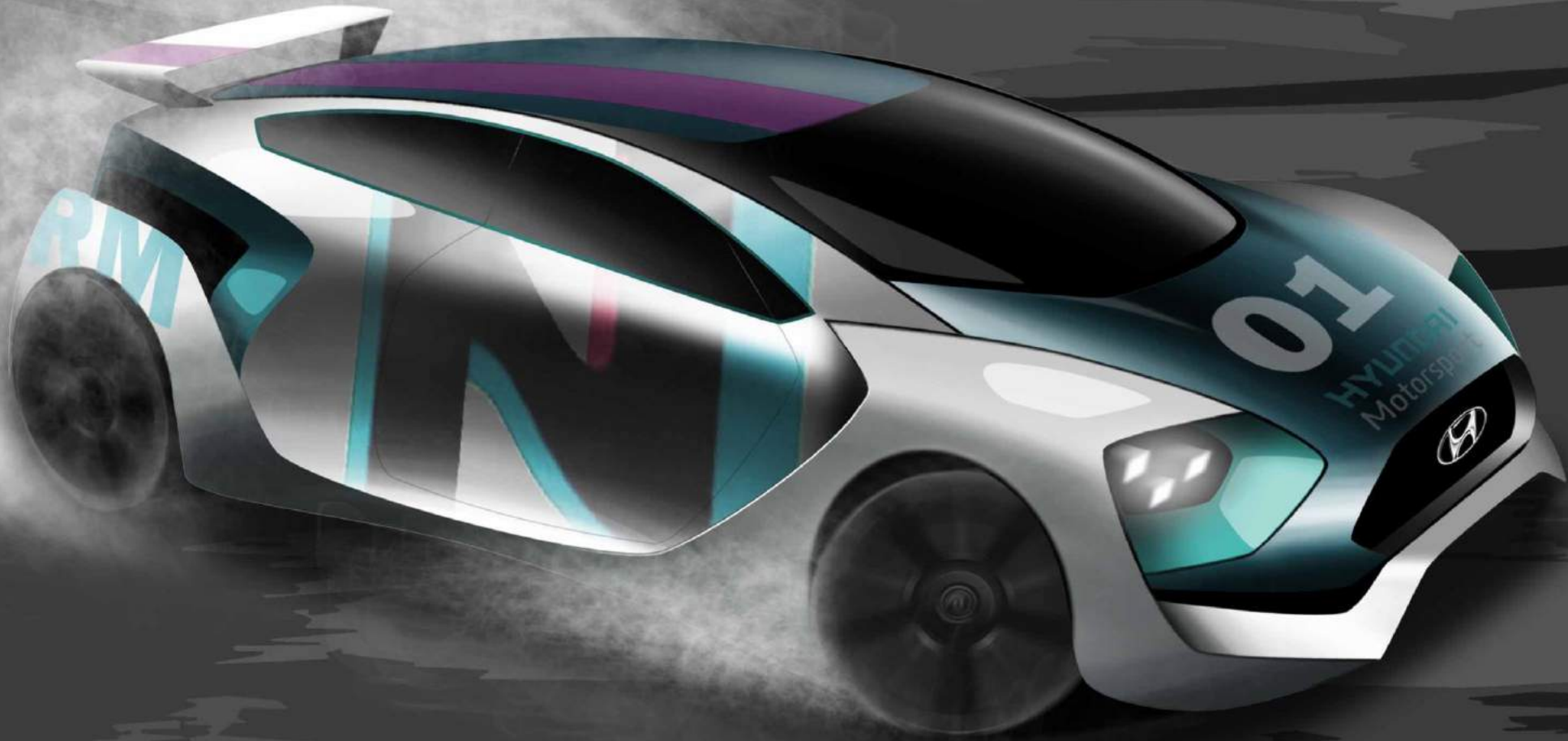

7559453363
pk.267099@gmail.com

Automotive Alias Skills (CAS)

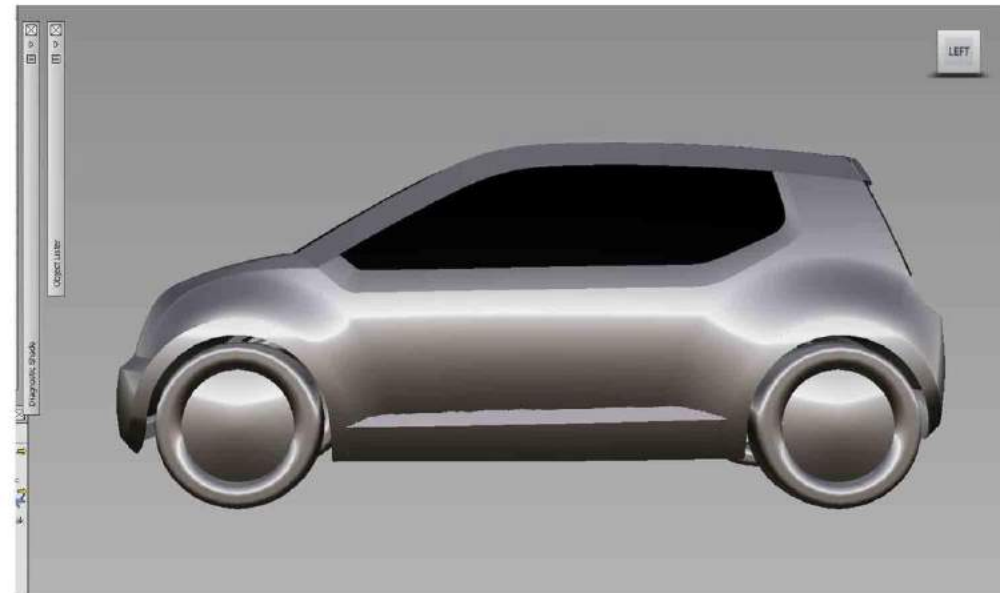
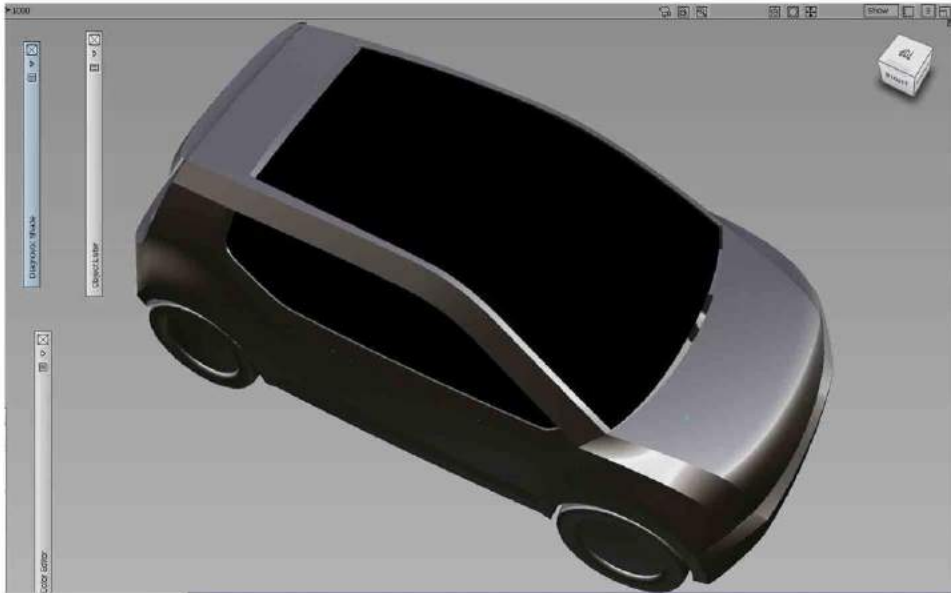
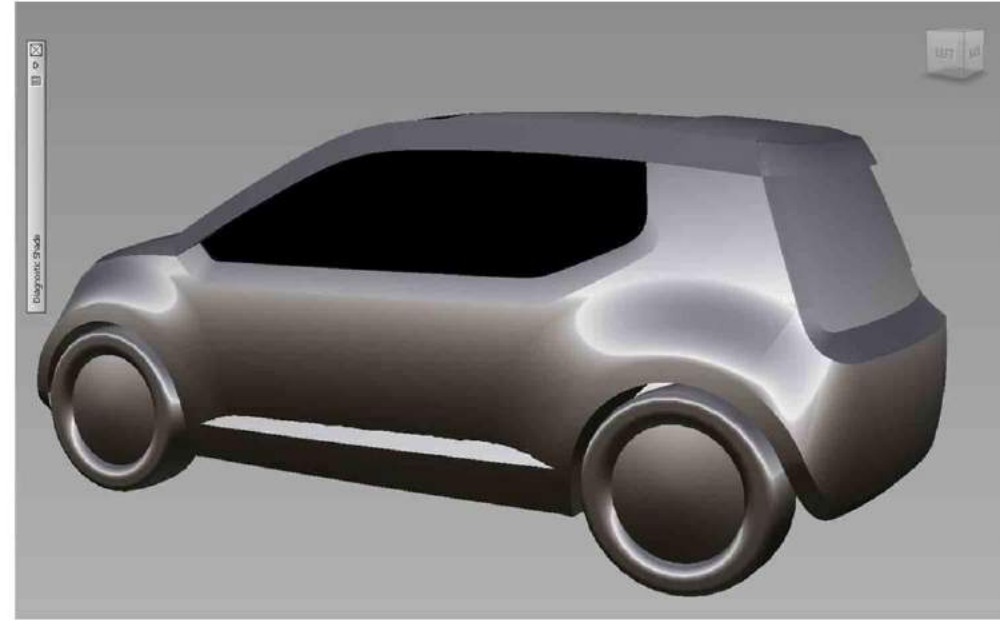
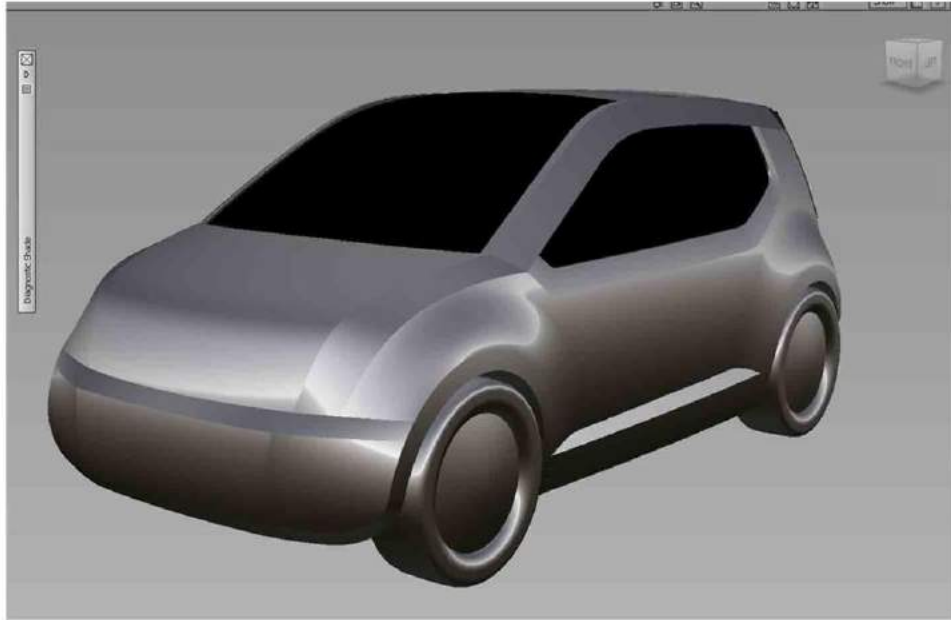

Automotive Alias Skills (CAS)

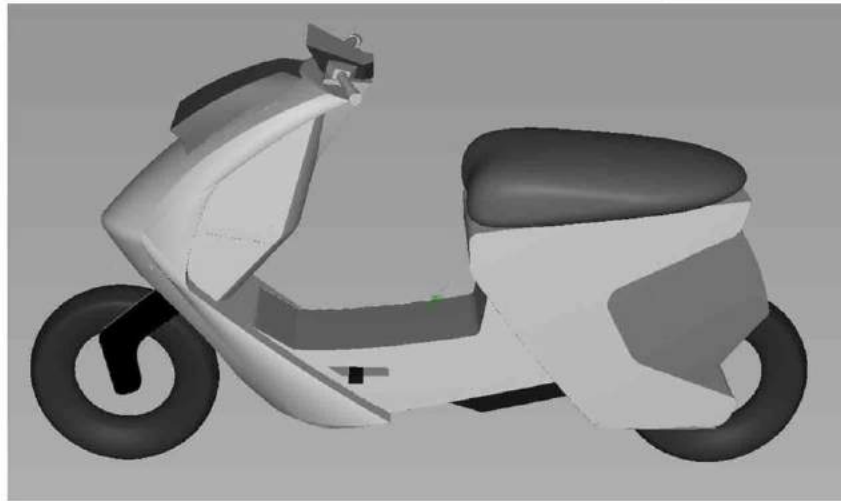
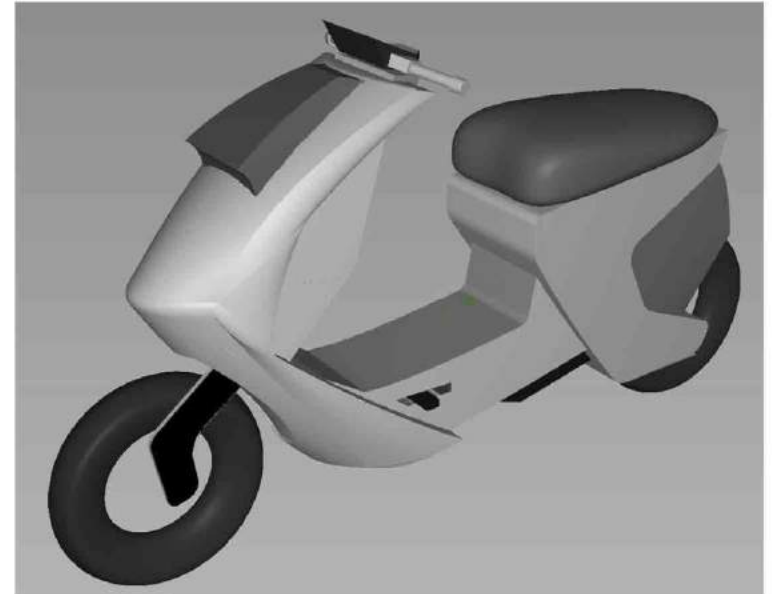
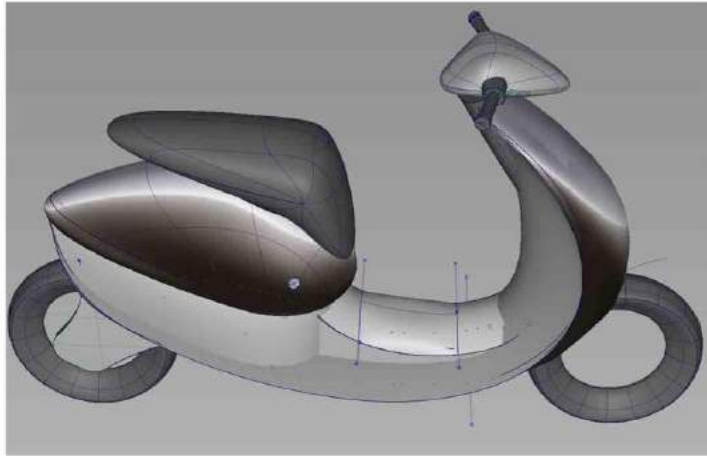

MOTORCYCLE SKETCHES

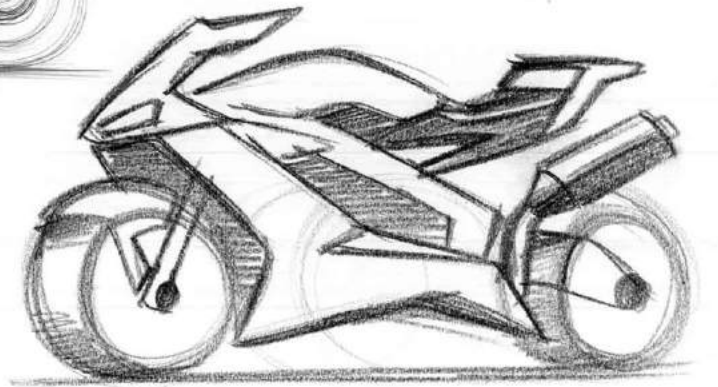
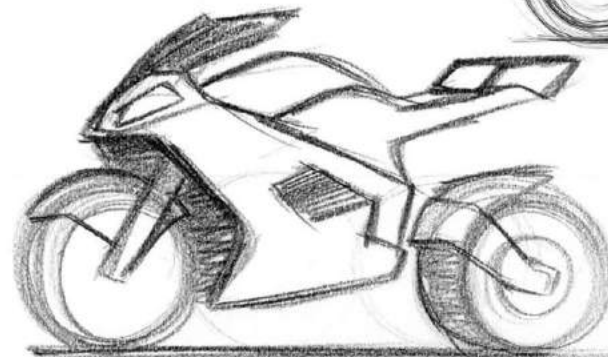
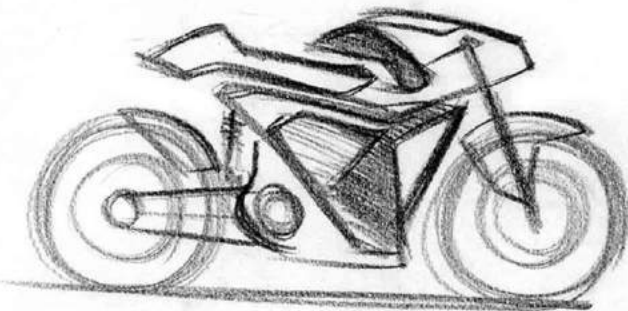
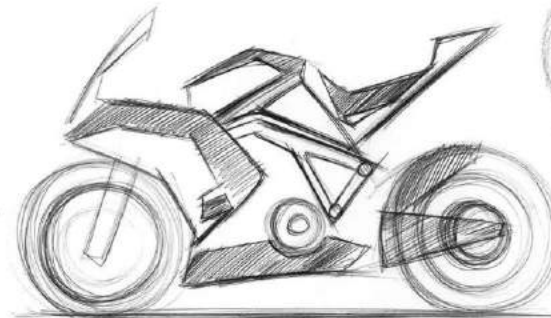
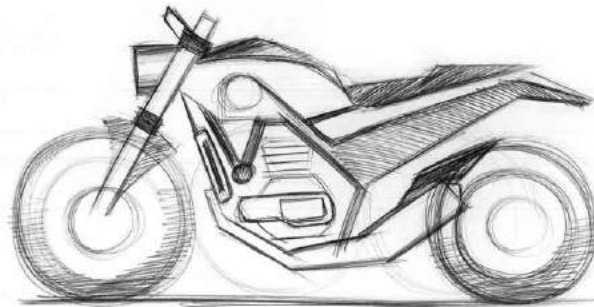
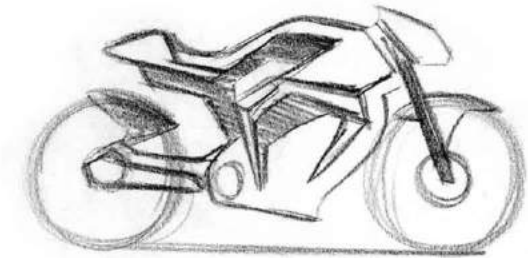
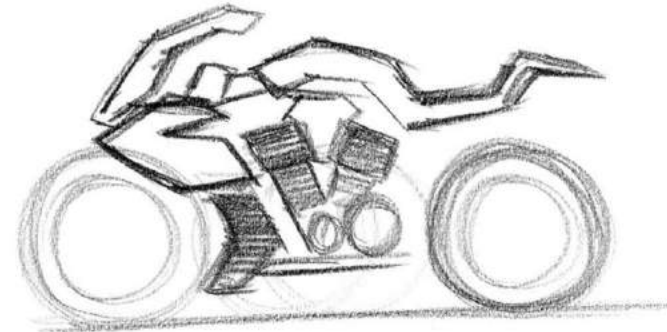
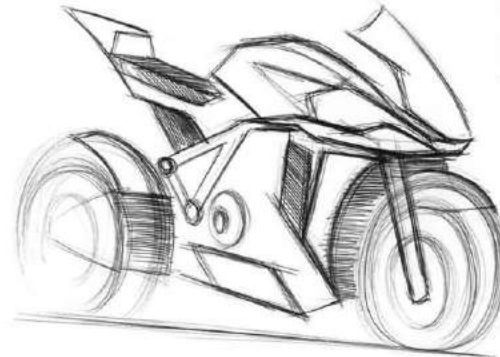
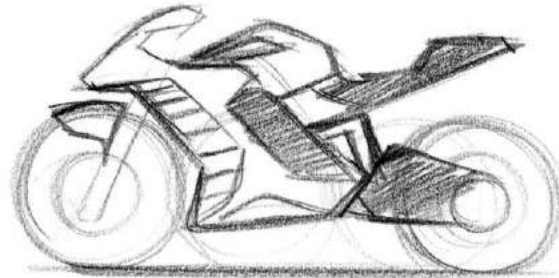
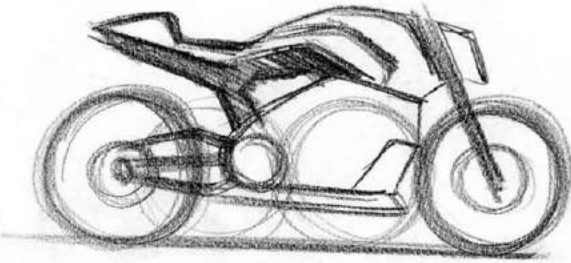
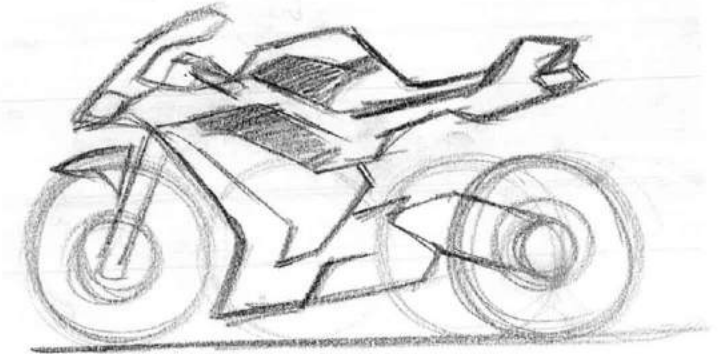
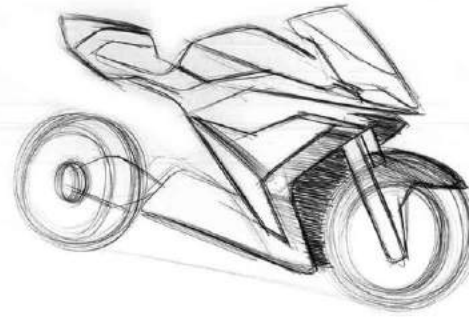
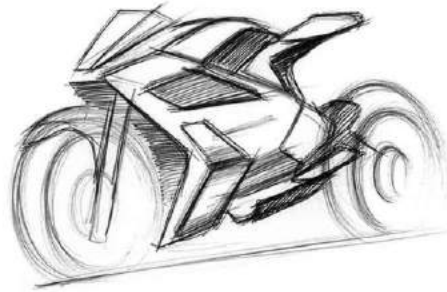
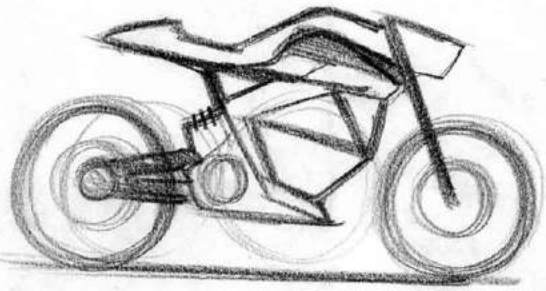

MOTORCYCLE SKETCHES

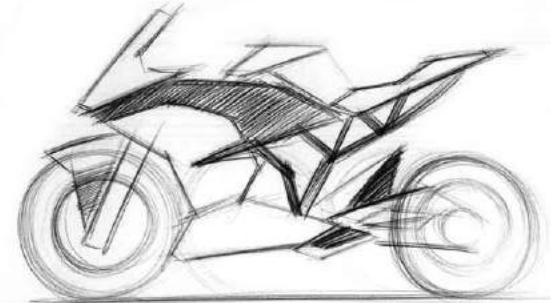
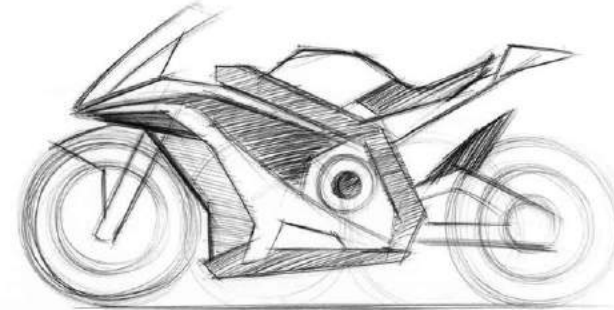
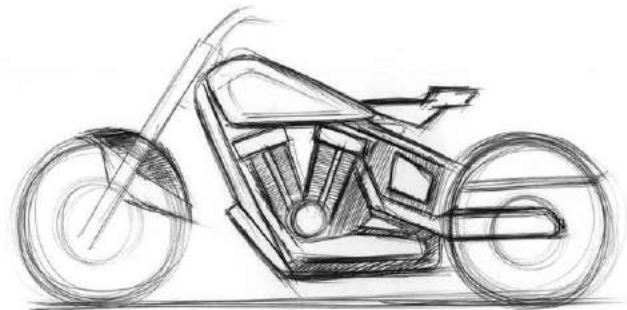
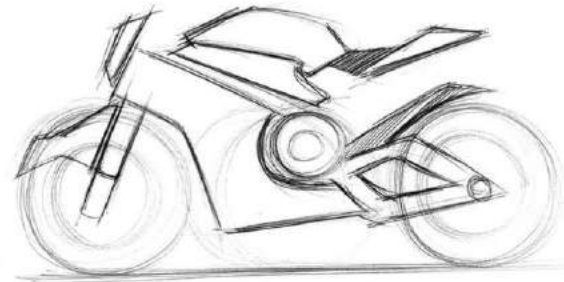
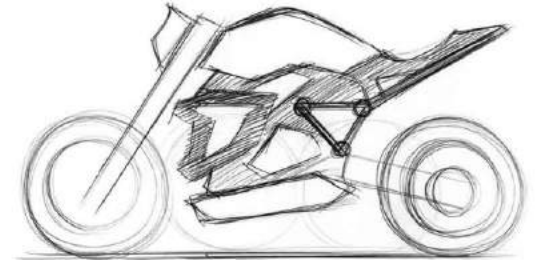
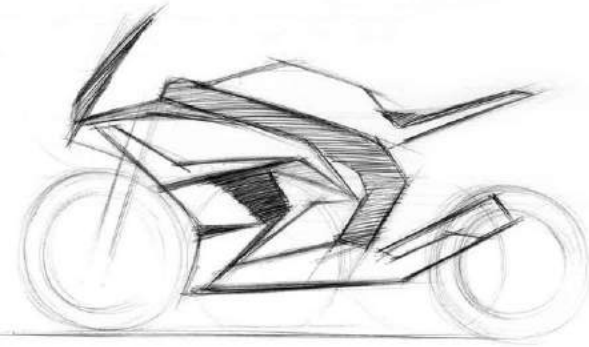
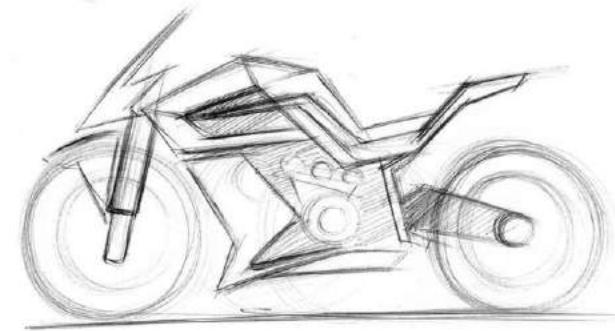
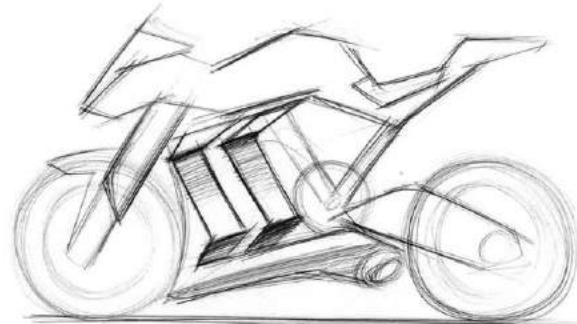
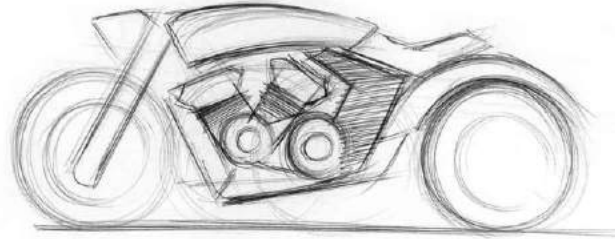
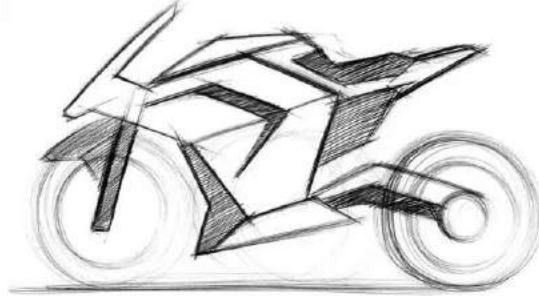
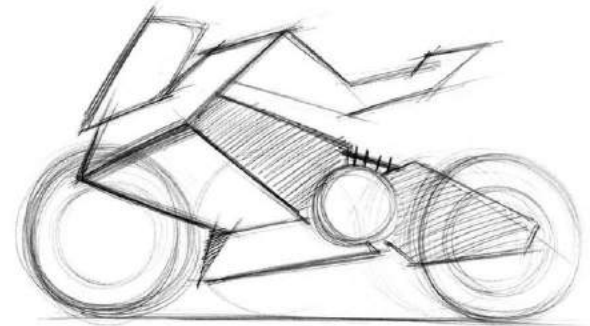
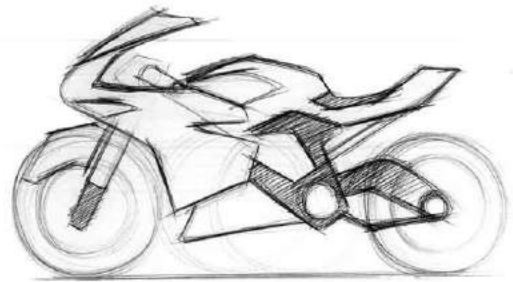
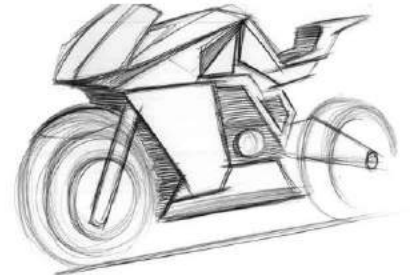
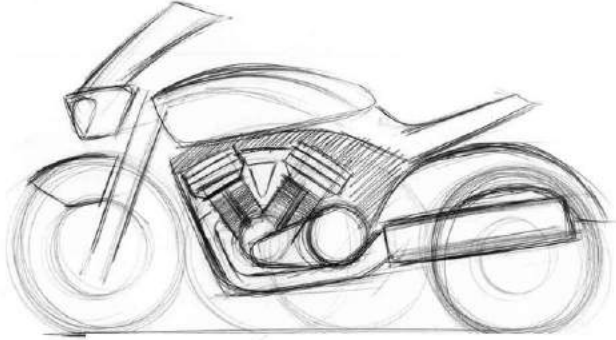
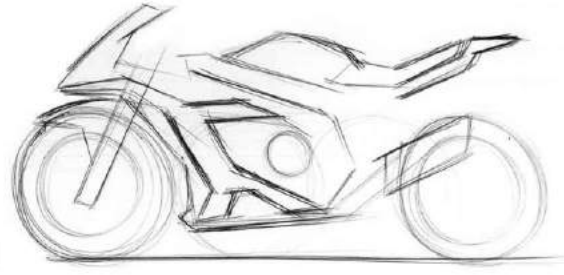
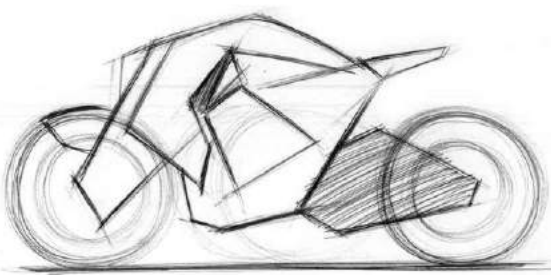

Thank You

Name ----- Prashant Khalkho
Degree -----Transportation Design (M.Des)
-----Mechanical (B.Tech)
Phone Number ----- 7559453363, 8084903244
Mail Id ----- pk.267099@gmail.com
-----prashant.khalkho@adypu.edu.in